



---

# Service Manual

## P80 CONSOLE

20039-179 REV A01



PRECOR CUSTOMER SUPPORT



# Contents

<b>Section 1 - Introduction .....</b>	<b>5</b>
About this Document .....	5
Safety Guidelines .....	5
<b>Section 2 - Verifying Proper Installation .....</b>	<b>7</b>
Equipment Base Cabling .....	7
P80 Power Requirements.....	7
Treadmill Specific Concerns.....	7
Cable Routing Through the P80 Armor .....	9
1-Stop Switch Cable Routing .....	10
2-RF Coax Cable Routing .....	11
3-Ethernet Cable Routing .....	13
4-Data Cable Routing .....	14
5-Auto-Stop Cable Routing .....	15
6-Power Cable Routing.....	16
7-Heart Rate Cable Routing.....	17
Mounting the P80 Console.....	18
Initial Configuration Steps.....	20
Steps to Perform on Each And Every P80 .....	20
Steps that can be Cloned (copied) .....	20
<b>Section 3 - Operation Verification .....</b>	<b>21</b>
Procedure.....	21
Operation Verification Checklist.....	23
<b>Section 4 - Accessing the Service Software Menus.....</b>	<b>25</b>
Settings Menu.....	25
About Menu .....	29
Equipment Usage Menu .....	32
System Settings Menu .....	34
<b>Section 5 - System Tests and Workout Limits .....</b>	<b>37</b>
System Tests.....	37
P80 Workout Limits.....	42
<b>Section 6 - Updating Software.....</b>	<b>45</b>
Acquiring P80 Software from the Precor FTP Site.....	46
Installing P80 software into the P80 console.....	49
Procedure .....	49
<b>Section 7 - Display and Entertainment Settings.....</b>	<b>55</b>
P80 Display .....	55
P80 TV Settings.....	59
Channel Guide .....	62
To scan for available channels: .....	62

---

To name a channel: .....	62
To delete a channel from the Channel Guide: .....	66
How to update the channel plan:.....	66
<b>Section 8 - Cloning Settings.....</b>	<b>69</b>
P80 Manage Settings (Cloning).....	69
P80 Manage Settings Table.....	69
P80 Cloning Procedure.....	71
<b>Section 9 - Connectivity and Registration.....</b>	<b>77</b>
P80 Connectivity .....	77
To view connectivity information:.....	77
P80 Connectivity Set Up and Registration Procedure .....	79
<b>Troubleshooting Procedures.....</b>	<b>83</b>
Verifying the Hardware Version.....	83
Boot Error resulting in Yellow Triangle Being Displayed.....	85
Possible Causes.....	85
Possible Remedies.....	85
Boot Error resulting in Red Triangle Being Displayed.....	86
Description.....	86
Possible Causes.....	86
Possible Remedies.....	86
Preva Net Panel Icon Not Displayed .....	87
Description.....	87
Possible Causes.....	87
Possible Remedies.....	87
Preva Net Panel Displayed but Web Pages and/or RSS Feeds Do Not Load.....	88
Description.....	88
Possible Causes.....	88
Possible Remedies.....	88
Sign-in Button Does Not Appear On the Welcome Screen.....	89
Description.....	89
Possible Causes.....	89
Possible Remedies.....	89
Black Screen - Full Console .....	90
Description.....	90
Possible Causes.....	90
Possible Remedies.....	90
Boot Screen Procedure.....	90
Poor Quality Video - Single Unit Only .....	91
Description.....	91
Possible Causes.....	91
Possible Remedies.....	91
Poor Quality Video - All Units .....	92
Possible Causes.....	92
Possible Remedies.....	92

Poor Quality Video - One Channel(s) or Limited Channels.....	93
Description.....	93
Possible Causes.....	93
Possible Remedies.....	93
Green Screen.....	94
Description.....	94
Possible Causes.....	94
Possible Remedies.....	94
Stuttering Channels.....	95
Description.....	95
Possible Causes.....	95
Possible Remedies.....	95
Touch Screen Slow Response .....	96
Description.....	96
Possible Causes.....	96
Possible Remedies.....	96
Touch Screen Responds Incorrectly to Touch or is Unresponsive .....	97
Description.....	97
Possible Causes.....	97
Possible Remedies.....	97
Screen Calibration Procedure .....	97
Poor Quality Video - One Channel or Limited Channels.....	98
Possible Causes.....	98
Possible Remedies.....	98
Poor Audio Quality - All Channels, Multiple Units.....	99
Description.....	99
Possible Causes.....	99
Possible Remedies.....	99
Machine Controls Unresponsive.....	100
Description.....	100
Possible Causes.....	100
Possible Remedies.....	100
Message Out of Service Displayed.....	101
Description.....	101
Possible Causes.....	101
Possible Remedies.....	101
Message Please Reset the Treadmill Displayed .....	102
Description.....	102
Possible Causes.....	102
Possible Remedies.....	102
Unit reboots of its own volition.....	103
Description.....	103
Possible Causes.....	103
Possible Remedies.....	103
Treadmill - Resets to Welcome Screen at Beginning of the "3...2...1..." Countdown.....	104
Description.....	104
Possible Remedies.....	104

---

USB Flash Drive Not Recognized.....	105
Description.....	105
Possible Causes.....	105
Possible Remedies.....	105
<b>Section 11 - Replacement Procedures.....</b>	<b>107</b>
Upper Component Access:.....	107
The Main Vented Access Cover & Components.....	108
Replacing the P80 Console.....	109
Console Mounting - Removal.....	109
Disconnecting Cables.....	110
Console Installation.....	112
Cable Connections.....	113
Securing the P80 Console.....	116
Replacing the P80 Heart Rate PCA Board.....	116
Procedure.....	116
<b>Section 12 - Wiring &amp; Block Diagrams.....</b>	<b>119</b>
<b>Section 13 - Replaceable Parts Identification.....</b>	<b>123</b>

# Section 1 - Introduction

---

## About this Document

Warning: This service manual is for use by Precor trained service providers only. If you are not a Precor Trained Servicer, do not attempt to service any Precor products. Call your dealer for service.

This document contains information required to perform the majority of troubleshooting and replacement procedures required to repair and maintain this product.

This document contains general product information, software diagnostic procedures (when available), preventative maintenance procedures, inspection and adjustment procedures, troubleshooting procedures, replacement procedures and electrical block and wiring diagrams.

## Safety Guidelines

Additional safety guidelines are included in the owner's manual.

Operate the equipment on a solid, level surface. Visually check the equipment before beginning service or maintenance operations. If it is not completely assembled or is damaged in anyway, do not attempt to operate the equipment.

To prevent electrical shock, keep all electrical components away from water and other liquids.

Do not use accessory attachments that are not recommended by the manufacturer-such attachments might cause injuries.





# Section 2 - Verifying Proper Installation

---

---

Cables connecting the P80 should be routed in a very specific order and in a very specific path to avoid damage to the cables. This section is a systematic process on how the cables should be routed through the P80 console. Functionality issues could occur if the cables have been routed in a manner other than described in this section. If you have a functionality problem with a P80 console, verifying that these cables were routed correctly prior to any other troubleshooting could save you time and frustration.

## Equipment Base Cabling

For cable routing through the specific equipment base, refer to the installation guide shipped with the specific equipment base type (TRM, EFX, AMT, RBK, and UBK).

## P80 Power Requirements

To operate the P80 requires a separate 12Vdc power supply. The 12Vdc power supply will be mounted to the inside of the frame of the treadmill using Velcro strips.

For ALL other units (because they are self powered) the 12Vdc power supply must be outside of the equipment covers, typically in a cable management "Tee" connector or other customer supplied cable management. Except for the TRM, make sure the power supply cable's ground lug is grounded to the equipment frame.

## Treadmill Specific Concerns

The cables entering the display support column should be routed from the side above the stop switch assembly, not through the hole at the bottom of the display support column. The cables should then be arranged in the clips in the display support column as shown below.

The ends of the cables should be routed through the display support column, behind the console mounting plate, and out through the hole in the center of the weldment. There should be a total of 7 cables (8 cables if you consider that the heart rate cable is physically 2 cables going into one connector) exiting the center hole in the console mounting plate.

Cables not routed in this manner can be pinched and/or damaged during installation.

*Figure 1: TRM Console Support & Cable Routing*

Clip the cables into the cable management

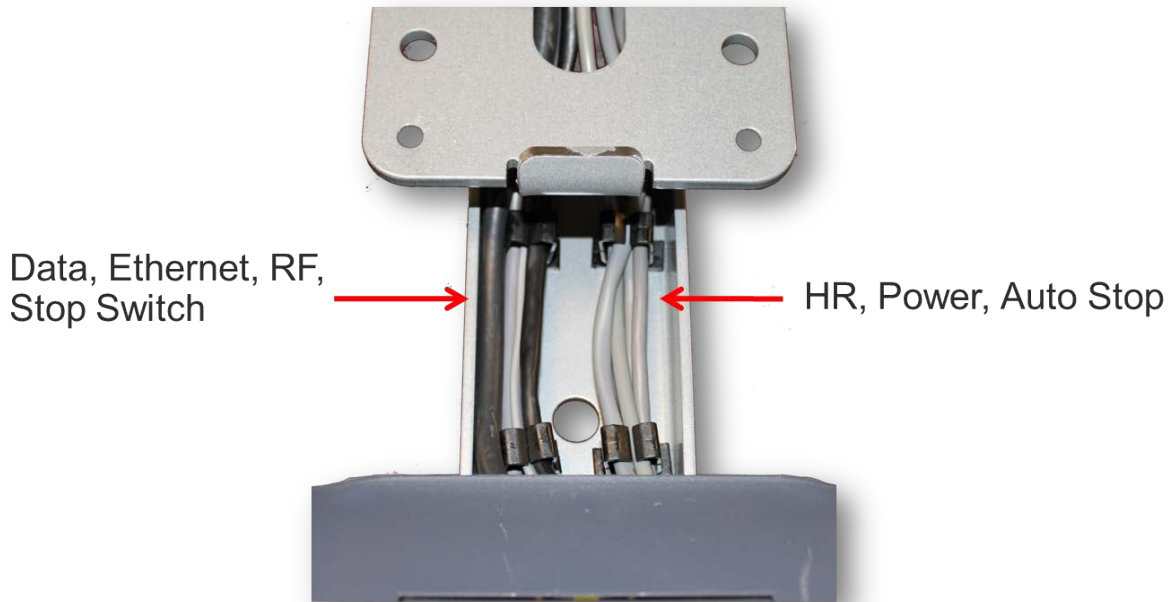

## Cable Routing Through the P80 Armor

In the back of the P80 console is a large black steel support, called the Armor. At the bottom of the unit's mounting plate there is a hook that holds the console in place, leaving your hands free to perform the cable routing steps. Remove the 4 console mounting screws and tilt the console forward, allowing the hook to support the console. Verify the cable routing against the following steps. Cables should be routed through the center of the armor and out specific side openings in the armor. The specific order and path that these cables are routed allow them to be attached to their respective connectors without being pinched and/or damaged.

### Cable Routing Order

- 1 Stop Switch Cable
- 2 RF Coax Cable
- 3 Ethernet Cable
- 4 Data Cable
- 5 Auto-Stop Cable
- 6 Power Cable
- 7 Heart Rate Cable

*Figure 2: Console on Mounting Hook*

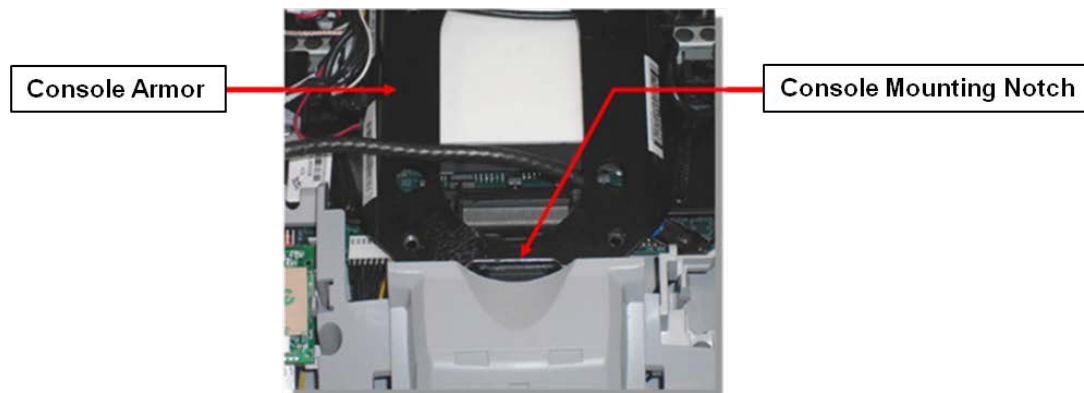

## 1-Stop Switch Cable Routing

The Stop Switch assembly cable (treadmill only) should be routed through the lower right corner of the armor, and connected to the 6 pin flat connector on the CPA board. The cable will go through the center of the armor, out the bottom right side opening, then up to the connector. Be sure to get the connector onto the six pins correctly or the treadmill will not work.

*Figure 3: Stop Cable Routing (Treadmill Only)*

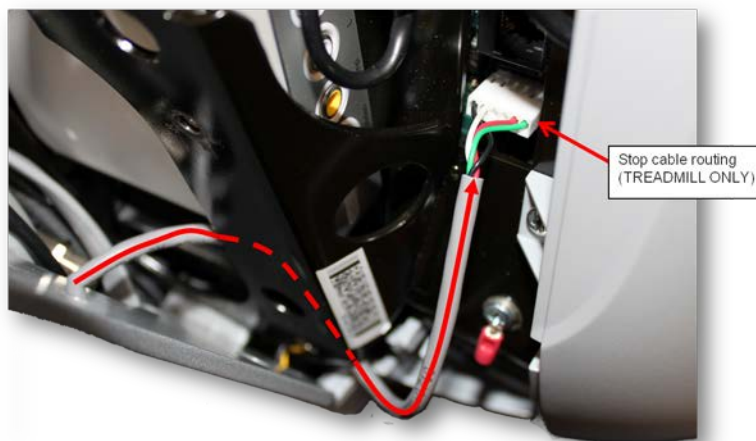

## 2-RF Coax Cable Routing

- a) The RF Coax cable should be routed down below the tuner, and out the right bottom side of the armor. This is easier if you straighten the cable and gently push it through the center of the armor, in the direction as shown. Use your finger to guide the cable out the bottom right side opening and feed about 10 inches through.

*Figure 4: Coax Cable Starting Path*



- b) The RF Coax cable should reach up and over the top of the armor connecting it to the flexible cable attached to the tuner.

---

***When connecting to the flexible cable, take care to not damage the cable. Being flexible, it is also fragile and can become damaged if handled roughly.***

---

*Figure 5: Coax Cable Ending Path*

Route the Coax Cable



- c) The RF Coax connector should be secured in place with the zip tie provided with the console. It is important that the connection be tied to the frame in this location to prevent the cable being pinched and possibly causing rattling noises during use. If the zip tie is missing, locate one and secure the connection. Be sure to get the zip tie on the connector and not on the cable.

*Figure 6: Coax Connector Zip Tie*

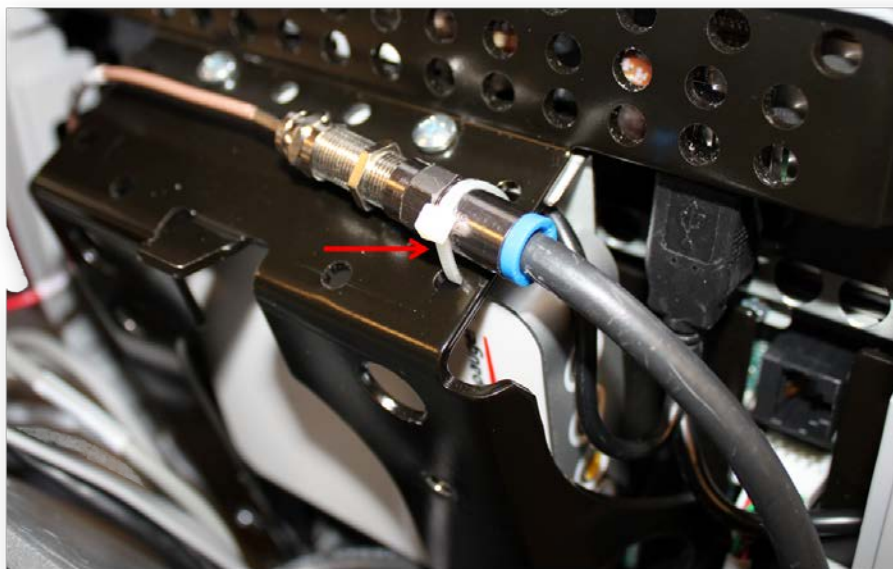

### 3-Ethernet Cable Routing

The Ethernet cable should be routed through the center of the armor, and then through the opening in the upper right side of the armor. The Ethernet cable connects to the upper RJ45 type connector. The Ethernet cable will always be black and round.

*Figure 7: Ethernet Cable Routing*

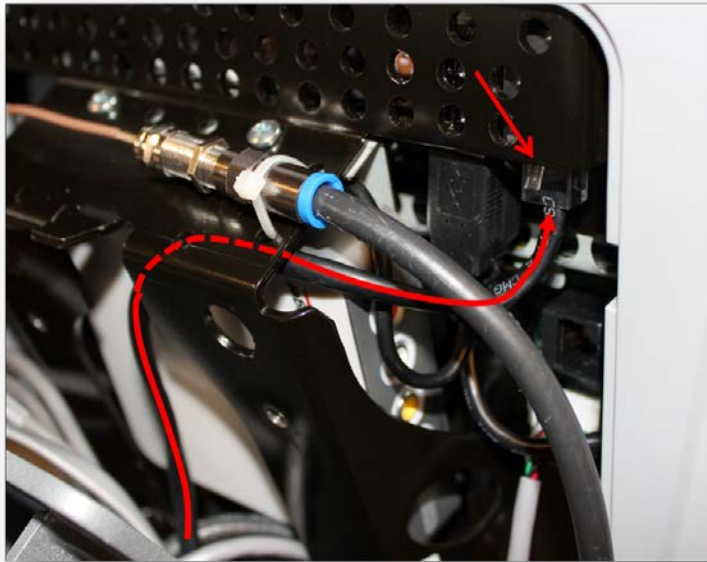

#### 4-Data Cable Routing

The Data cable should be routed through the center of the armor, and then through the opening in the upper right side of the armor. The Data cable attaches to the lower RJ45 type connector. The data cable will always be grey and flat.

*Figure 8: Data Cable Routing*

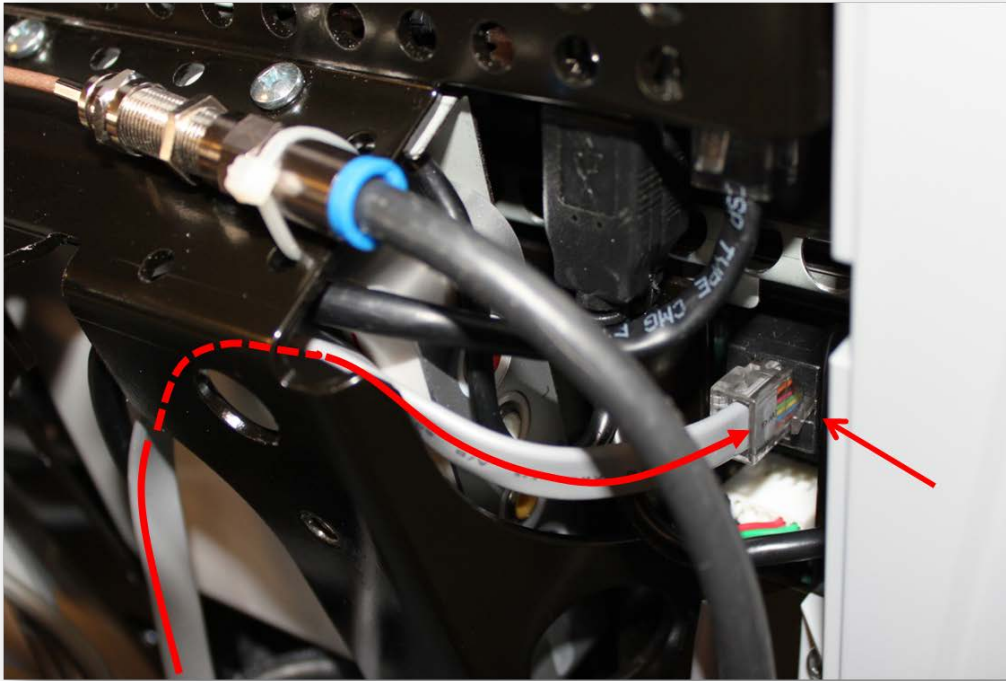



## 5-Auto-Stop Cable Routing

The Auto Stop cable (treadmill only) should be routed through the center of the armor, and then through the upper left corner of the weldment. The connector will be a four pin keyed connector.

*Figure 9: Auto Stop Cable Routing*

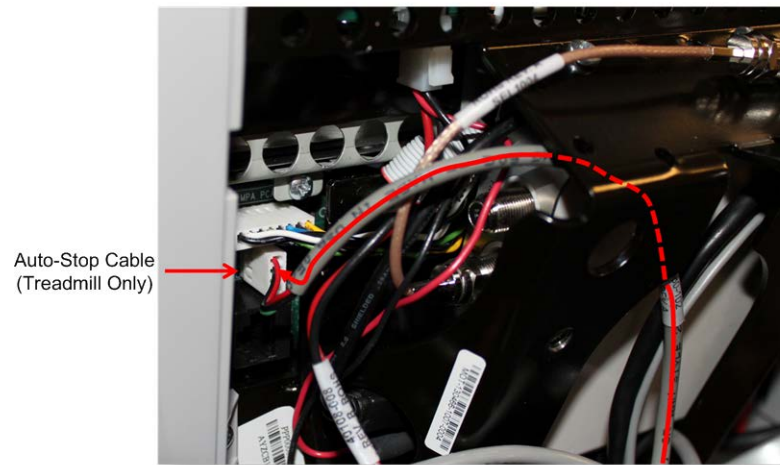

## 6-Power Cable Routing

The Power cable should be routed through the center of the armor, and then through the upper left corner of the weldment. If the P80 is hardware version 1, It is possible that when you are dressing the cables to pull this connector back inside the weldment. Leave the connector on the side of the P80 as shown, as it might be necessary to access it for troubleshooting. Version 1.5 hardware will connect to the power supply board.

*Figure 10: 1\_5 Power Cable Routing (Prior to version 1.5 Hardware)*

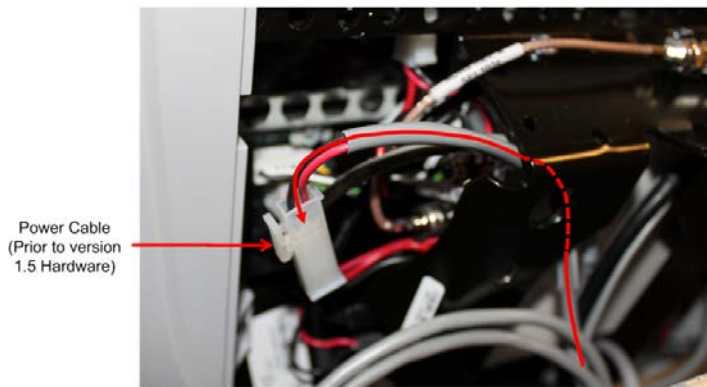

*Figure 11: Power Cable (Version 1.5 Hardware or Later)*

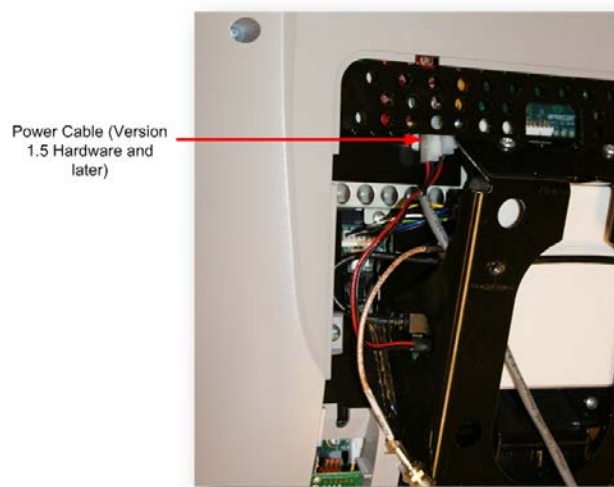

## 7-Heart Rate Cable Routing

The Heart Rate cable should be routed through the center of the armor, and then through the upper left corner of the weldment. Route any excess Heart Rate cable into the rectangular center section of the dash assembly.

*Figure 12: Heart Rate Cable Routing*

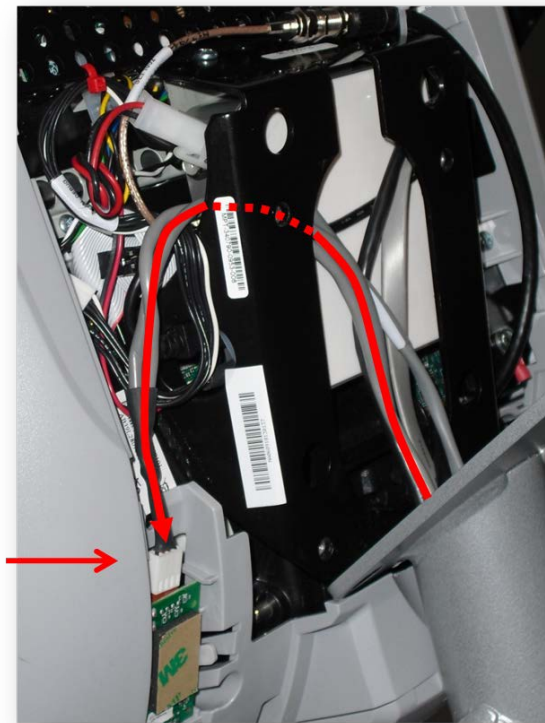

## Mounting the P80 Console

- 1 Double check that all cables are fully and securely connected, and that cables are tied back properly. Make sure any extra cabling is pulled down through the neck.

---

**NOTE:**

**\*\*\*For treadmill installations, make sure that the cables from the upright to the mounting neck are routed along the front of the dash (using the attached flex ties), making sure the cables are routed through the plastic guides inside the neck.\*\*\***

---

*Figure 13: Dash Cable Routing*

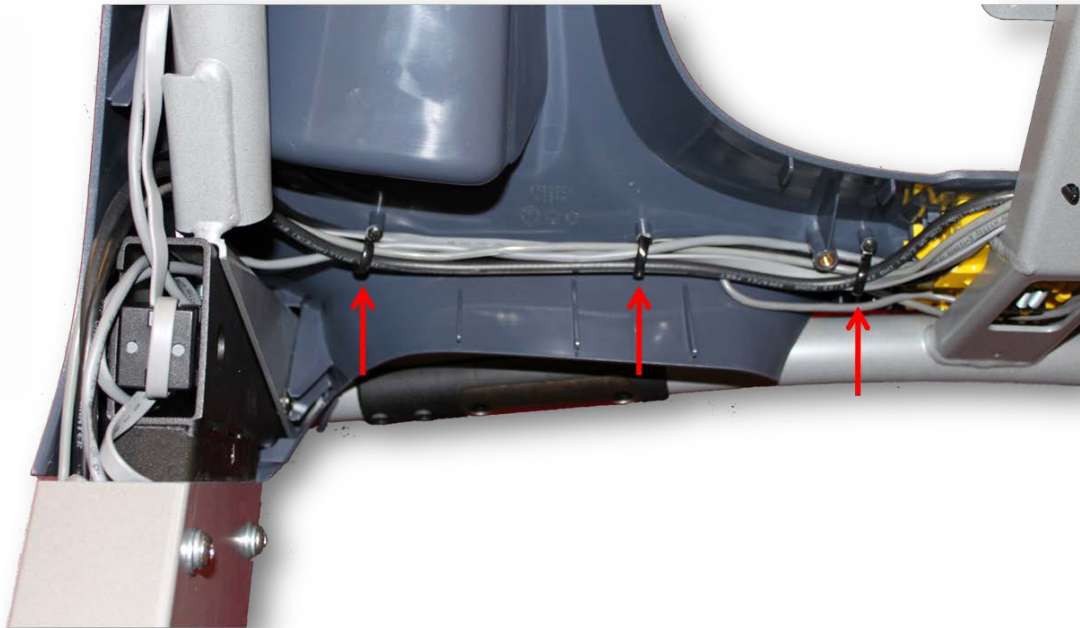

- 2 Tilt the control console back onto the mounting plate until the tab on the top edge of the armor slides along the top edge of the mounting plate and the screw holes align properly.
- 3 Secure the console to the plate using the four flat head 5/8 inch long screws in the hardware kit. Use the 5/8 inch long screws that come in the hardware kit, as they are a custom length for this location. If you need additional screws (part number [MCCN025-031](#)) contact Precor. 1/2 inch screws are too short to provide the proper grounding required by the P80 and 3/4 inch are too long and can damage wires.

*Figure 14: Console Mounting Screws*

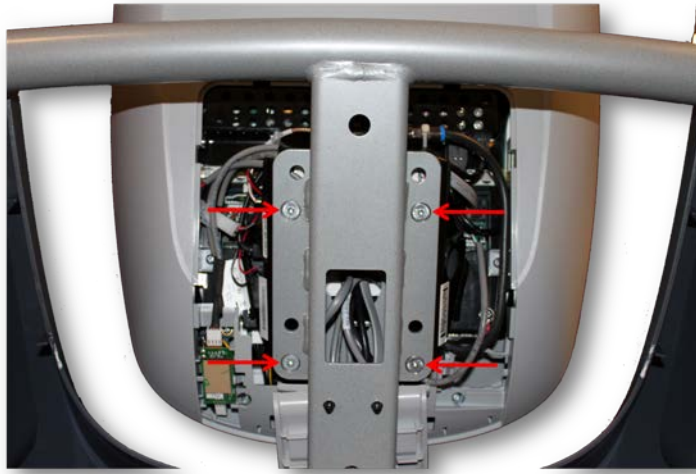

- 4 Tighten the screws fully using a  $\frac{5}{32}$ -inch hex wrench.

## Initial Configuration Steps

After the P80 is physically installed, it must be configured for the specifics of the facility (TV settings, network settings, etc.). Below are the steps that need to be performed for the configuration, and in the order they need to be performed.

## Steps to Perform on Each And Every P80

These are settings that are unique to each specific P80, and therefore can't be cloned (copied) from console to console.

- Verify that the software is at the current version, and update if necessary per procedure, ***Updating Software*** (see "***Section 6 - Updating Software***" on page 45).
- Connect the P80 to the facilities network per procedure, ***Connectivity and Registration*** (see "***Section 9 - Connectivity and Registration***" on page 77).
- Register the P80 with Preva® Business Suite per procedure, ***Connectivity and Registration*** (see "***Section 9 - Connectivity and Registration***" on page 77).

## Steps that can be Cloned (copied)

These are the settings that can be set-up on one P80, and then cloned to all the other P80s at that facility.

- Perform a channel scan, per procedure, ***Display and Entertainment Settings*** (see "***Section 7 - Display and Entertainment Settings***" on page 55).
- Name all channels, per procedure, ***Display and Entertainment Settings*** (see "***Section 7 - Display and Entertainment Settings***" on page 55).
- Save configuration and clone to all other P80s per procedure, ***Cloning Settings*** (see "***Section 8 - Cloning Settings***" on page 69).

# Section 3 - Operation Verification



This section provides a quick method of checking the proper operation of the P80. Proper operation of the P80 should be verified at the end of any maintenance procedure. The following procedure assumes a fully operational console that has been properly installed and connected to video and network sources. In addition, the console must also have been registered and a channel scan completed.

## Procedure

- 1 Plug the power cord into the wall outlet (or turn on the treadmill with its breaker switch). Verify that the P80 "Boots Up" to the "Welcome" screen (the boot sequence will take some time).

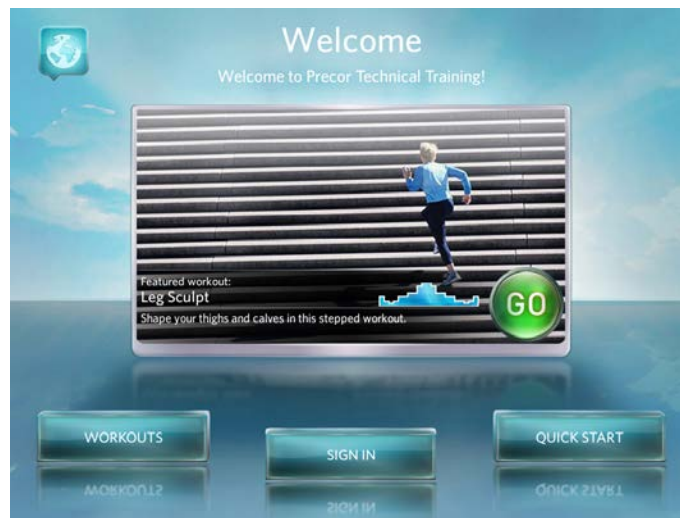
*Figure 15: Welcome Screen*







- 2 Press the "Quick Start" button on the touch screen and verify that the unit starts the manual workout program.
- 3 Verify that the machine control lever(s) operate(s) the appropriate machine functions of the equipment base.
  - Press RESISTANCE  (SPEED  on a treadmill) lever in the up direction and verify that resistance level or speed has been increased.

- Press RESISTANCE ↓ (SPEED ↓ on a treadmill) lever in the down direction and verify that resistance level or speed has been decreased.
  - If the unit has a variable cross ramp or lift, press INCLINE ↑ lever in the up direction and verify that the incline travels in the up direction.
  - If the unit has a variable cross ramp or lift, press INCLINE ↓ lever in the down direction and verify that the incline travels in the down direction.
  - If the P80 is connected to a treadmill, pull the E-stop lanyard and verify that the screen displays "Reset the Treadmill" along with a picture of the E-stop switch in the "UP" position.
- 4 Set the touch screen to view the "Entertainment Panel" and verify that TV channels are displayed.
- Verify that the current channel is displayed in the preview window.
  - Press one of the other channels in the list on the touch screen and verify that the channel changes in approximately 3 seconds.
  - Press the channel up switch and verify that the channel changes in approximately 3 seconds.
  - Press the channel down switch and verify that the channel changes in approximately 3 seconds.
  - Plug in a set of headphones and verify that sound is present at both ears.
  - Press the volume up switch and verify that the volume increases.
  - Press the volume down switch and verify that the volume decreases.
- 5 If "Preva® Networked Fitness" option is activated, verify that the Preva® net panel icon is displayed.
- Press the Preva® net panel icon and verify the Preva® net panel appears.
  - Press the "ALL" button and verify that a list of RSS feeds appears.
  - Press the "Go" button and verify that the RSS article loads and is displayed on the screen. Viewing an RSS article also verifies that the P80 is capable of web access.



## Operation Verification Checklist

- P80 "Boots Up" to the "Welcome" screen.
- Machine begins work out after pressing "Quick Start".
- Machine controls are functional.
- P80 can display TV channels.
- TV channels change using both touch screen controls and channel  and  buttons.
- Audio is present at the headphone jack, and volume is controlled using the volume  and  buttons.
- (Networked P80s only) Preva<sup>®</sup> net panel displayed, and RSS feeds can load from the internet.



# Section 4 - Accessing the Service Software Menus

## Settings Menu

- 1 The **Welcome** screen will be the first screen you see when the P80 console boots up.
- 2 From the Welcome screen, press the Pause key and continue holding it down while you press in sequential order an X configuration on the Volume and Channel keypad (① Channel Up, ② Volume Down, ③ Volume Up, ④ Channel Down). Release the Pause key when done pressing the arrows.

**Note: The keypad X configuration sequence should be not faster than 1 second between each key stroke. Any speed faster than 1 second may result in an unsuccessful access to the sign-in screen.**

Figure 16: P80 Sign In Access

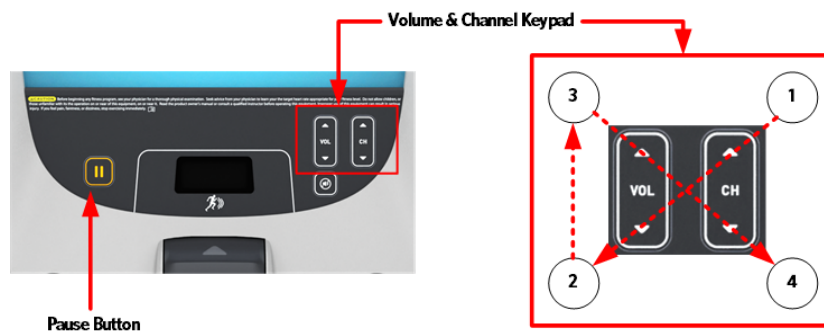

- 3 After entering the "X" pattern above, the sign-in screen will be displayed.

*Figure 17: Sign-In Screen*



- 4 Type in the technician access 5,1,7,6,5,7,6,1, and then touch OK. The Settings menu will be displayed.

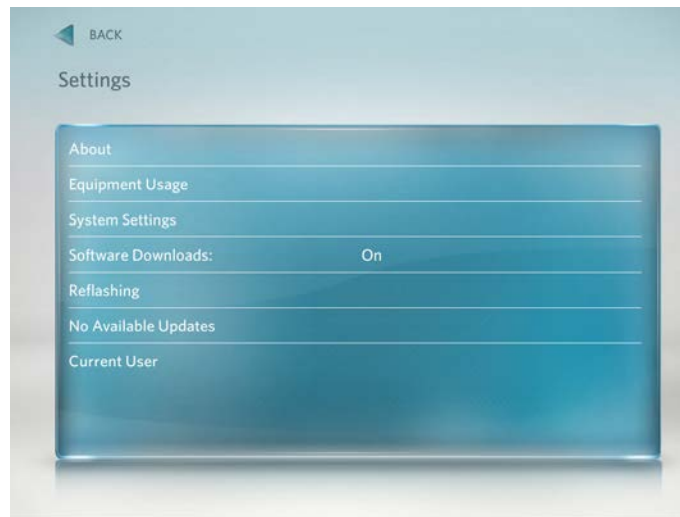

*Figure 18: Settings Screen*



- 5 Use the Settings Menu to configure settings in ways that benefit the users and the facility, or for testing the equipment specifications. Changes made to these settings will be saved to the fitness equipment. To select a Setting touch on an item in the Settings menu. See the following **Settings Menu** Table for a description of each menu item.

## P80 Settings Menu Table

Menu Item	Description	Navigation	Configure/View/Test
<b>About</b>	System information screens provide basic information including equipment models and serial numbers. Most of these screens are for informational purposes only and cannot be modified.	Touch <b>About</b>	See Procedure, <i><b>About Menu</b></i> (on page 29)
<b>Equipment Usage</b>	The Equipment Usage screens provide information on individual usage as well as cumulative equipment usage. This information on these screens is accessible only to administrators and Precor service technicians.	Touch <b>Equipment Usage</b>	See Procedure, <i><b>Equipment Usage Menu</b></i> (on page 32)
<b>System Settings</b>	Use the System Settings to test your equipment and set parameters that benefit your users and your facility. The System Settings menu is visible only to administrators and Precor service technicians.	Touch <b>System Settings</b>	See Procedure, <i><b>System Settings Menu</b></i> (on page 34)
<b>Software Downloads</b>	Toggled ON or OFF, this setting allows software to be automatically updated through the Preva® network.  It is recommended that this remain ON at all times. Contact Precor Customer Service before this setting is disabled.	Touch <b>Software Downloads</b>	Touch radio button next to On to Enable Automatic Downloads.  Default is ON  Touch radio button next to Off to Disable Automatic Downloads.
<b>Reflashing</b>	The P80 is equipped with advanced boot-error recovery features. These settings are used to view and control software boot images. These settings are used during a manual software update, and for advanced troubleshooting with Precor assistance only.	Touch <b>Reflashing</b>	View and/or change the active software boot image.

Menu Item	Description	Navigation	Configure/View/Test
<p><b>Available Updates</b></p> <p>Or</p> <p><b>No Available Updates (Default)</b></p>	<p>The default is "No Available Updates". When a USB flash drive is installed that contains a valid software package, Available Updates will be displayed.</p>	<p>Touch <b>Available Updates</b></p>	<p>Touch the radio button next to the desired available update.</p> <p>Touch View to see the details of the software bundle. Touch  <b>BACK</b> to return to updates list.</p> <p>Touch Install to load the update into the console.</p> <p>See Procedure, <i>Updating Software</i> (see "<i>Section 6 - Updating Software</i>" on page 45).</p>
<p><b>Current User</b></p>	<p>The log indicates current user's access level.</p>	<p>Touch <b>Current User</b></p>	<p>Touch  <b>BACK</b> to exit.</p>

Touch  **BACK** to exit Settings.

## About Menu

- 1 From the "Settings" menu, press "About". The "About" menu will be displayed as below.

*Figure 19: Settings to About*



- 2 The About menu provides information about hardware and software events and console build configuration. Most of these screens are for informational purposes only and cannot be modified.

### P80 About Menu Table

Menu Item	Descriptions	Configure/View/Test
<b>Event Log</b>	Provides a list of the most recent hardware and software events, and equipment status.	<p>Details of the Event will be listed.</p> <p>Touch <b>REFRESH</b> to update the list in the log.</p> <p>Touch <b>SAVE</b> to save the log to a Flash drive device.</p> <p>Touch <b>← BACK</b> to exit</p>
<b>Console Serial Number</b>	Set by user and stored in the console's memory.	Information Only
<b>Lower Serial Number</b>	Stored in the console's memory. Note: This information is not currently available to be displayed.	Information Only
<b>Location</b>	Entered on user console.	<p>Touch <b>LOCATION</b> to change the location.</p> <p>Displays location information.</p> <p>Touch <b>← BACK</b> to exit</p>
<b>Release Bundle Version</b>	Shows current version of software.	<p>Displays detailed information about the current software.</p> <p>Touch <b>← BACK</b> to About</p>
<b>Etag Check Interval:</b>	Determines how often the console will check for updates.	Information Only
<b>Heartbeat Interval</b>	Determines how often the console communicates with the Server.	Information Only
<b>Minimum Heartbeat Interval</b>	Minimum amount of time between heartbeats to the Preva <sup>®</sup> server.	Information Only
<b>Maximum Heartbeat Interval</b>	Maximum amount of time between heartbeats to the Preva <sup>®</sup> server.	Information Only
<b>MFE MAC (Media</b>	Stored in the consoles memory. Set at	Information Only



<b>Menu Item</b>	<b>Descriptions</b>	<b>Configure/View/Test</b>
<b>Access Code) Address</b>	factory. This is a hardware address that uniquely identifies each node of a network.	
<b>Network Time Server 1</b>	These addresses are set at the factory and will not need to be changed in the field.	Information Only
<b>Network Time Server 2</b>	These addresses are set at the factory and need be changed in the field.	Information Only <b>.Note: They can be manually changed.</b>
<b>Network Time Server 3</b>	These addresses are set at the factory and need be changed in the field.	Information Only
<b>Machine Type</b>	Type of equipment (AMT, RBK, UBK, EFX, & TRM). Set at factory.	Information Only

Touch  **BACK** to exit "About" (back to "Settings" menu).

## Equipment Usage Menu

- 1 From the "**Settings**" menu, press "Equipment Usage". The "**Equipment Usage**" menu will be displayed as below.

*Figure 20: Settings to Equipment Usage*



- 2 The Equipment Usage settings provide information on Cumulative Equipment usage. See the following **P80 Equipment Usage Menu Table**.

### P80 Equipment Usage Menu Table

Menu or Information Item	Description	Detail or Test
<b>Cumulative Workout Seconds</b>	Total number of seconds. Seconds are counted when the workout clock starts	Information Only
<b>Cumulative Workout Distance</b>	<ul style="list-style-type: none"> <li>◆ Treadmills will report miles of use.</li> <li>◆ AMTs will report a horizontal distance as miles.</li> <li>◆ Ellipticals will convert total strides to miles.</li> <li>◆ Bikes will convert total revolutions to miles</li> </ul>	Information Only
<b>Cumulative Work Out Sessions</b>	Total number of sessions. A session is counted if the summary screen displays.	Information Only
<b>Total Belt Strides -AMT12 Only</b>	Reports the cumulative total strides for the Machine.	Information Only
<b>Last Workout Start Date Time</b>	The date of the start of the last workout.	Information Only
<b>Last Workout End Date Time</b>	The date of the end of the last workout.	Information Only

Touch  **BACK** to exit "Equipment Usage" (back to "Settings" menu).

## System Settings Menu

- 1 From the "Settings" menu, press "System Settings". The "System Settings" menu will be displayed as below.

*Figure 21: Settings to System Settings*



- 2 Use the System Settings to test your equipment and set parameters that benefit your users and your facility. See the following **P80 System Settings Menu Table**.

## P80 System Settings Menu Table

<b>Menu or Information Item</b>	<b>Description</b>	<b>Navigation</b>	<b>Configure/View/Test</b>
<b>Systems Test</b>	The systems tests allow you to check specific functions of the equipment.	Touch <b>Systems Test</b>	See Procedure, <b><i>System Tests</i></b> (on page 37).
<b>Connectivity</b>	The connectivity screens allow you to configure or provides information about the equipment's network connection.	Touch <b>Connectivity</b>	See Procedure, <b><i>P80 Connectivity</i></b> (on page 77).
<b>Display</b>	The display settings allow you to configure, Measurement units, Standby Mode Delay, Internet Browser Access, Preva® Net Panel.	Touch <b>Display</b>	See Procedure, <b><i>P80 Display</i></b> (on page 55).
<b>TV Settings</b>	TV Settings help you set up television channels for your users.	Touch <b>TV Settings</b>	See Procedure, <b><i>P80 TV Settings</i></b> (on page 59).
<b>Work out Limits</b>	The Workout Limit settings give you control over how the equipment is used. Use these settings to create reasonable limitations for equipment usage including speed, incline, resistance, and duration.	Touch <b>Workout Limits</b>	See Procedure, <b><i>P80 Workout Limits</i></b> (on page 42).
<b>Register Equipment</b>	After Connectivity has been set up the equipment can be registered.	Touch. <b>Register Equipment</b>	See Procedure, <b><i>Connectivity and Registration</i></b> (see " <b><i>Section 9 - Connectivity and Registration</i></b> " on page 77)
<b>Manage Settings</b>	Use this setting to save your equipment settings to a USB flash drive, or to import settings from a USB flash drive.	Touch <b>Manage Settings</b>	See Procedure, <b><i>P80 Manage Settings (Cloning)</i></b> (on page 69).

Touch  **BACK** to exit "Equipment Usage" (back to "Settings" menu).



# Section 5 - System Tests and Workout Limits

## System Tests





- 1 From the "Settings" menu, press "System Settings", and then press "System Tests". The "System Tests" menu will be displayed as below.

Figure 22: Settings to System Settings to System Tests







- 2 The systems tests allow you to check specific functions of the equipment.
- 3 To select a Systems Test touch on an item in the Systems Test menu. See the following **P80 Systems Test Menu Table**.



## P80 System Test Menu Table

Test	Equipment	Description
<b>Auto Stop Test</b>	TRM Only	<ol style="list-style-type: none"> <li>1 Touch <b>Auto Stop Test</b>, then Touch <b>START</b>.</li> <li>2 The Auto stop test will start the belt at 1 mph; count will be reset to 0, and then count up with each step.</li> <li>3 Touch <b>STOP</b> to end the test. Touch  <b>BACK</b> to exit to <b>Systems Test</b>.</li> </ol>
<b>Belt Speed Test</b>	TRM Only	<ol style="list-style-type: none"> <li>1 Touch <b>Belt Speed Test</b>, then Touch <b>START</b>.</li> <li>2 The belt will start a 0.5 mph, using the machine control paddle to increase by 0.1 mph increments. The console will display motor current as the belt speed increases or decreases.</li> <li>3 Touch <b>STOP</b> to end the test. Touch  <b>BACK</b> to exit to <b>Systems Test</b>.</li> </ol>
<b>Incline Test</b>	TRM, Open Stride AMT	<ol style="list-style-type: none"> <li>1 Touch <b>Incline Test</b>, and then Touch <b>START</b>.</li> <li>2 Use the machine control paddle to change the lift. The console will display the analog to digital (A/D) incline position number, the incline position in percent of incline, and the Glitch incline position.</li> <li>3 Touch <b>STOP</b> to end the test. Touch  <b>BACK</b> to exit to <b>Systems Test</b>.</li> </ol>
<b>AMT Stride Position Test</b>	AMT Only	<ol style="list-style-type: none"> <li>1 Touch <b>AMT Stride Position Test</b> and then Touch <b>START</b>.</li> <li>2 The High, Low and Dynamic positions will be displayed. The low position display shows the lowest position reading achieved during the test. The high position display shows the highest position reading achieved during the test. The dynamic position display changes with current stride position. At maximum stride length the low stride display should read 0 and the high stride display should read 40.</li> <li>3 Touch <b>STOP</b> to end the test. Touch  <b>BACK</b> to exit to <b>System Tests</b>.</li> </ol>



Test	Equipment	Description
<b>Brake Test</b>	AMT, RBK, UBK, EFX	<ol style="list-style-type: none"> <li>1 Touch <b>Brake Test</b>, then Touch <b>START</b>.</li> <li>2 Use the machine control paddle to change the resistance up and down. The resistance changes will be displayed in power bits.</li> <li>3 Touch <b>STOP</b> to end the test. Touch  <b>BACK</b> to <b>Systems Test</b>.</li> </ol>
<b>Battery Test</b>	AMT, RBK, UBK, EFX	<ol style="list-style-type: none"> <li>1 Touch <b>Battery Test</b>, and then Touch <b>START</b>.</li> <li>2 The console will display the voltage of the battery.</li> <li>3 Touch <b>STOP</b> to end the test. Touch  <b>BACK</b> to <b>Systems Test</b>.</li> </ol>
<b>SPM</b>	AMT, EFX	<ol style="list-style-type: none"> <li>1 Touch <b>SPM Test</b>, and then <b>START</b>.</li> <li>2 The console will display Pulse. The pulse is showing a count of zero crossings from the generator. SPM shows a software averaged version of pulse. An averaged pulse per minute will display as Minimum and a Maximum pulse.</li> <li>3 Touch <b>STOP</b> to end the test. Touch  <b>BACK</b> to exit to <b>Systems Tests</b>.</li> </ol>
<b>RPM Test</b>	RBK, UBK	<ol style="list-style-type: none"> <li>1 Touch <b>RPM Test</b>, and then <b>START</b>.</li> <li>2 The console will display Pulse. The pulse is showing a count of zero crossings from the generator. RPM shows a software averaged version of pulse.</li> <li>3 Touch <b>STOP</b> to end the test. Touch  <b>BACK</b> to exit to <b>Systems Test</b>.</li> </ol>
<b>Cross Ramp</b>	EFX Only	<ol style="list-style-type: none"> <li>1 Touch <b>Cross Ramp Test</b>, and then Touch <b>START</b>.</li> <li>2 Use the machine control paddle to change the Cross Ramp. The console will display the analog to digital (A/D) and Glitches incline position number. Dynamic available battery voltage to the lift system will be displayed.</li> <li>3 Touch <b>STOP</b> to end the test. Touch  <b>BACK</b> to <b>Systems Test</b>.</li> </ol>

<b>Test</b>	<b>Equipment</b>	<b>Description</b>
<b>USB Test</b>	All	<ol style="list-style-type: none"> <li>1 Touch <b>USB Test</b>.</li> <li>2 The USB Test will show the number of USB ports currently active, there should be six. Insert a USB Flash drive into the USB port and then Touch <b>CLOSE</b>, and then Touch <b>USB Test</b> again. The number of active USB ports should be increased by one.</li> <li>3 Touch <b>CLOSE</b> to exit to <b>Systems Test</b>.</li> </ol>
<b>Touchscreen Test</b>	All	<ol style="list-style-type: none"> <li>1 Touch <b>Touchscreen Test</b>.</li> <li>2 Place your finger on one corner of the screen and run it around the edges multiple times.</li> <li>3 The line drawn by your finger should be very close to previous passes. Be sure that you do not touch anything else with your other hand.</li> <li>4 Touch <b>FINISH</b> to exit to <b>Systems Test</b>.</li> </ol>
<b>Touchscreen Calibration</b>	All	<ol style="list-style-type: none"> <li>1 Touch <b>Touchscreen Calibration</b>.</li> <li>2 A + will be displayed on a white screen. Touch the +, the spot you just touched will disappear and then be replaced with another + in a different location on the white screen.</li> <li>3 Continue to touch the + as they appear on the screen until the test automatically exits to the <b>Systems Test</b> screen. You cannot exit this test until all the + have been touched and the screen is calibrated.</li> </ol>
<b>Backlight Test</b>	All	<ol style="list-style-type: none"> <li>1 Touch <b>Backlight Test</b></li> <li>2 The backlight will display three levels of brightness, 100%, 60%, and 0% in succession in 1 second intervals, returning to the <b>System Tests</b> menu when complete.</li> </ol>
<b>RGB Test</b>	All	<ol style="list-style-type: none"> <li>1 Touch <b>RGB Test</b>.</li> <li>2 The full screen should move through a succession of five colors, requiring a touch anywhere on the screen to advance to the next. These are Red, Green, Blue, Black, White, returning to the <b>Systems Tests</b> menu when all the displayed colors have been touched.</li> </ol>
<b>Speaker Test</b>	All	<ol style="list-style-type: none"> <li>1 Touch <b>Speaker Test</b>.</li> <li>2 This test will send an audible sound to the speaker mounted in the headphone jack and while providing a graphic of a scrolling bar on the screen. When the test is complete it will automatically exit to the <b>Systems Test</b> screen.</li> </ol>

Test	Equipment	Description
<b>Numeric Backlight Test</b>	All	<ol style="list-style-type: none"> <li>1 Touch Numeric <b>Backlight Test</b>.</li> <li>2 This tests the back lights of the lower display just above the paddle controls. The back lights of the display will illuminate in sequence in the Backlight Test and then automatically exit to the <b>Systems Test</b> screen.</li> </ol>
<b>Numeric Display Test</b>	All	<ol style="list-style-type: none"> <li>1 Touch Numeric <b>Display Test</b>.</li> <li>2 This will test the numeric LCD display just above the machine control levers. All the numeric characters will be displayed in sequence and then automatically exit to the <b>Systems Test</b>.</li> </ol>
<b>Heart Rate</b>	All	<ol style="list-style-type: none"> <li>1 Touch <b>Heart Rate</b>.</li> <li>2 Grasp both of the heart rate grips on the handlebar, the heart rate will be displayed after a couple of seconds.</li> <li>3 Use a wireless heart rate strap or wireless heart rate simulator, the heart rate will be displayed after a couple of seconds.</li> <li>4 Touch  <b>BACK</b> to exit to <b>Systems Test</b>.</li> </ol>
<b>Step Count Reset</b>	AMT12 Only	<p><b>Note: Do this only when replacing the flat belts.</b></p> <ol style="list-style-type: none"> <li>1 Touch <b>Step Count Reset</b>. <ul style="list-style-type: none"> <li>◆ The screen will display:</li> <li>◆ Current total step count</li> <li>◆ Step Count Reset</li> <li>◆ Odometer Value at the last reset.</li> </ul> </li> <li>2 During this step it is necessary to pedal the AMT while the Step Count is being reset, touch <b>START</b>. <ul style="list-style-type: none"> <li>◆ The Current Total Step Count will go to "0".</li> <li>◆ The Step Count Reset will increment up.</li> <li>◆ The Odometer will display the total miles recorded at the time of the reset.</li> </ul> </li> <li>3 Touch  <b>BACK</b> to <b>System Tests</b>.</li> </ol>

4 Touch  **BACK** to exit "System Tests" (back to "System Settings" menu).

## P80 Workout Limits

The Workout Limit settings give you control over how the equipment is used. Use these settings to create reasonable limitations for equipment usage including speed, incline, resistance, and duration. (Non-touch screen consoles refer to these as "Club Settings")

- 1 From the "Settings" menu, press "System Settings", and then press "Workout Limits". The "Workout Limits" menu will be displayed as below.

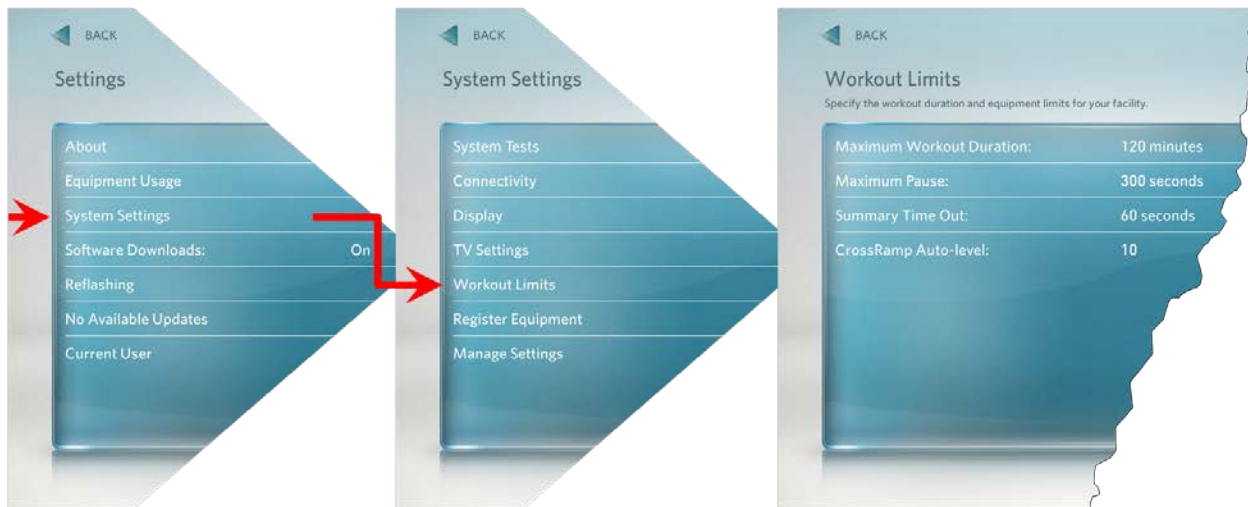

*Figure 23: Settings to System Settings to Workout Limits*



- 2 To select a Workout Limit setting, touch on an item in the Workout Limits menu. See the following P80 Workout Limits Menu Table.

## P80 Workout Limits Menu Table

Settings	Settings Options	Factory Default	Configure/View/Test
<b>Maximum Workout Duration</b>	Use the on-screen keypad or the up and down arrows to enter the maximum workout duration allowed on this fitness equipment.	60 minutes	<p>Touch <b>Maximum Workout Duration</b>.</p> <ol style="list-style-type: none"> <li>1 The on-screen keypad will appear,</li> <li>2 Enter the desired duration using the keypad. If an error was made while typing in the duration number, press the back space key on the keypad to delete the last entry.</li> <li>3 Touch <b>FINISH</b> to exit to the Workout Limits screen.</li> </ol>
<b>Maximum Pause Time</b>	<ul style="list-style-type: none"> <li>◆ 1 second</li> <li>◆ 5 seconds</li> <li>◆ 15 seconds</li> <li>◆ 30 seconds</li> <li>◆ 60 seconds</li> <li>◆ 120 seconds</li> <li>◆ 300 seconds</li> </ul>	30 seconds	<ol style="list-style-type: none"> <li>1 Touch <b>Maximum Pause Time</b>.</li> <li>2 Touch on a radio button next to the desired time, a dot will then fill the radio button next to the selection.</li> <li>3 Touch <b>OK</b> to exit to the Workout Limits Settings menu.</li> </ol>
<b>Summary Time Out</b>	<ul style="list-style-type: none"> <li>◆ No Time Out</li> <li>◆ 30 seconds</li> <li>◆ 60 seconds</li> <li>◆ 120 seconds</li> </ul>	60 seconds	<ol style="list-style-type: none"> <li>1 Touch <b>Summary Time Out</b>.</li> <li>2 Touch on a radio button next to the desired time, a dot will then fill the radio button next to the selection.</li> <li>3 Touch <b>OK</b> to exit to the Workout Limits Settings menu.</li> </ol>
<b>Resistance Range (RBK, UBK only)</b>	<ul style="list-style-type: none"> <li>◆ Low</li> <li>◆ Medium</li> <li>◆ High</li> </ul>	High	<ol style="list-style-type: none"> <li>1 Touch <b>Resistance Range</b></li> <li>2 Touch on the radio button next to Low, Medium, or High, a dot will fill the radio button next the selection.</li> <li>3 Touch <b>OK</b> to exit to the Display menu.</li> </ol>

<b>Settings</b>	<b>Settings Options</b>	<b>Factory Default</b>	<b>Configure/View/Test</b>
<b>Speed Limit (TRM only)</b>	1-16 mph	16 mph	<ol style="list-style-type: none"> <li>1 Touch <b>Speed Limit</b></li> <li>2 The on-screen keypad will appear, enter the desired duration using the keypad.</li> <li>3 Touch <b>FINISH</b> to exit to the Workout Limits screen.</li> </ol>
<b>Incline Limit (TRM only)</b>	<p>TRM 883 Cross Ramp incline range can be set to 0%-15%.</p> <p>TRM 885 Cross Ramp incline range can be set to 0% to 15% Note: the incline range is -3% to 15% but the limit can only be set from 0% to 15%</p>	15	<ol style="list-style-type: none"> <li>1 Touch <b>Incline Limit</b></li> <li>2 The on-screen keypad will appear, enter the desired duration using the keypad.</li> <li>3 Touch <b>FINISH</b> to exit to the Workout Limits screen.</li> </ol>
<b>Auto Stop (TRM only)</b>	<ul style="list-style-type: none"> <li>◆ ON</li> <li>◆ OFF</li> </ul>	ON	<ol style="list-style-type: none"> <li>1 Touch <b>Auto Stop</b></li> <li>2 Touch on a radio button next to either <b>ON/OFF</b>, a dot will then fill the radio button next to the selection.</li> <li>3 Touch <b>OK</b> to exit to the Workout Limits menu.</li> </ol>
<b>Cross Ramp Auto Level (EFX only)</b>	Cross Ramp Auto level settings are from 1% to 20%	10	<ol style="list-style-type: none"> <li>1 Touch <b>Cross Ramp Auto Level</b></li> <li>2 Touch the   to move auto level to the desired setting.</li> <li>3 Touch <b>OK</b> to exit to the Workout Limits menu.</li> </ol>

Touch  **BACK** to exit "Workout Limits" (back to "System Settings" menu).

# Section 6 - Updating Software

---

---

The P80 console is driven by software with innovative features that enhances the user's experience during a workout. Periodically the software will need to be updated with improvements to the functionality and features. This procedure explains how to update the software using a USB Flash drive that has at least 1GB of empty space.

## **Verifying Hardware Compatibility**

Since the initial release of the P80 there have been hardware and software updates. Before updating software you should verify what hardware version is installed, and if it is compatible with the software version you are updating to. There are 2 methods of determining the hardware version:

### **Method 1 – The Event Log:**

Reboot the P80. Once the P80 fully boots to the "Welcome" screen, go into the service access menus and press "ABOUT", then press "EVENT LOG". Look for an entry that begins with "OMAP" and look for the word "Hardware".

Hardware1 = 256K memory (early P80s)

Hardware2 = 512K memory

Hardware3 = includes new dual power supply

### **Method 2 – Part Number Dash:**

On the back of the P80 armor behind the vent cover, look for the part number label.

Part number with -101, or -601 only = 256K memory (early P80s)

Part number with -102, or -602 = 512K memory

Part number with -103, or -603 only = includes new dual power supply

## Acquiring P80 Software from the Precor FTP Site

### Procedure:

- 1 Open Windows Explorer on a desk top or laptop computer. Note Windows Explorer is a file manager application that is included with releases of the Microsoft Windows operating system from Windows 95 onwards.

---

***NOTE: Windows Explorer (otherwise known as "My Computer") should not be confused with Internet Explorer (otherwise known as an internet browser).***

---

To open your Windows Explorer:

- a) From your keyboard press and hold down the Windows key then press the E key.

*Figure 24: Windows Keyboard*



- 2 Type in **ftp://ftp2.precor.com** in the address field of the Windows Explorer exactly as it is written, a WWW or http prefix is not needed. Press Enter.

*Figure 25: Precor FTP Site*

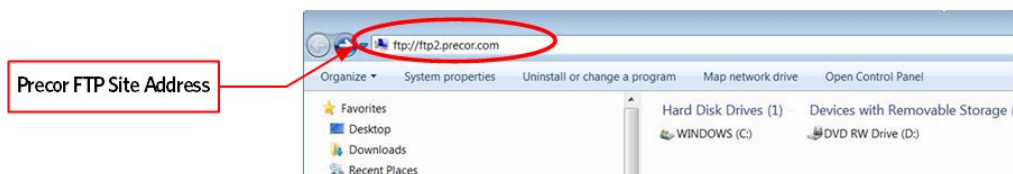

- 3 At the log in screen type in the user name: atlascust and the password: Luvnl1fe

---

***Note: the password is case sensitive. Select Logon.***

---

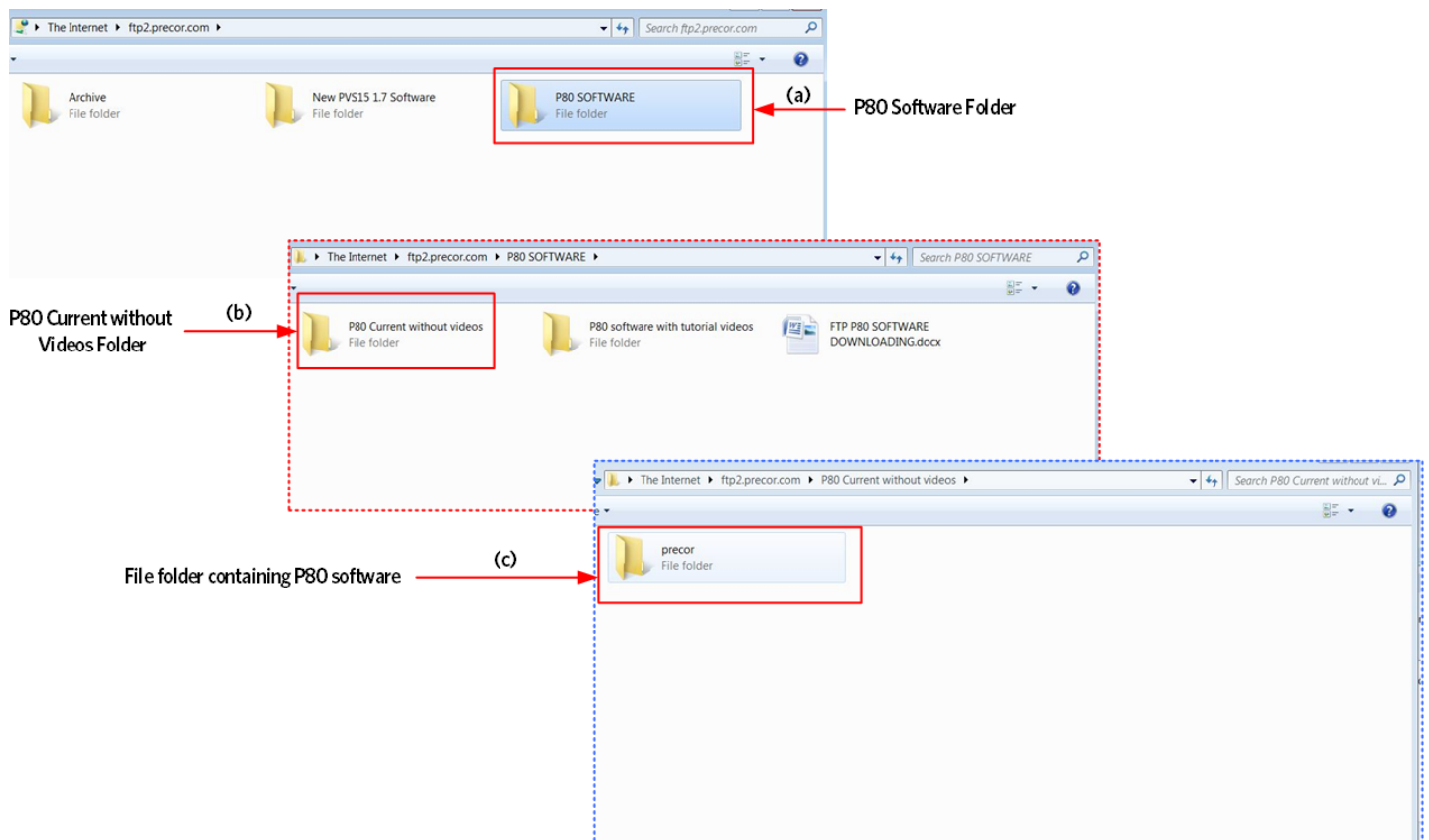

Figure 26: FTP site - User Name and Password



- 4 A successful logon will open the Precor FTP site. Open the file folder labeled P80 Software (a) and then open the file folder labeled, P80 Current without videos (b).
- 5 The P80 Current without videos folder will contain the P80 software (c).

Figure 27: Precor FTP site folders



- 6 Copy the Precor folder containing the P80 software by dragging it from the P80 Current without videos folder to your computer's desktop.

---

**Note: Copying and pasting the file folder directly to the USB Flash Drive may take a considerable amount of time or possibly time out. It is recommended to copy the file to your desktop first.**

---

- 7 Using the mouse, right click on the Precor folder containing the P80 software and select Copy.
- 8 Insert a flash drive device into your computer's USB port, when the removable disk drive appears in the list under Computer, select it.

*Figure 28: Flash Drive Device*

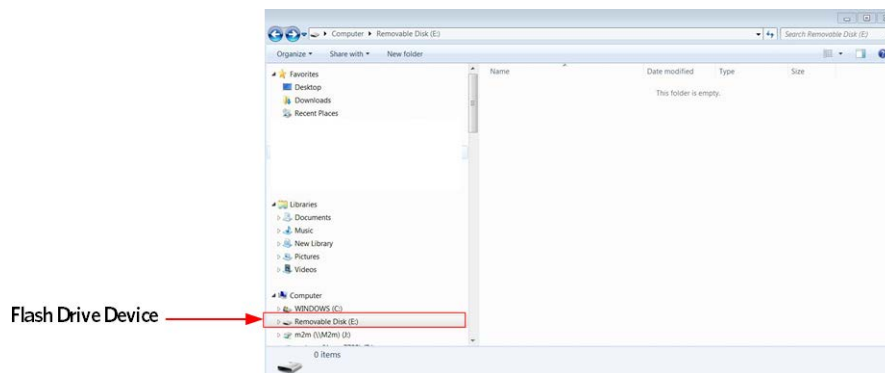

- 9 Right click the mouse on the removable disk and select Paste. The Precor folder containing the P80 software will then be copied onto the flash drive device. The P80 software on the flash drive is now ready to download onto the P80 consoles.
- 10 Right click the mouse on the removable disk and select "eject" prior to removing the flash drive from the USB port. The computer will respond with a message that it is safe to remove hardware, and then you can remove the flash drive from the USB port.

---

**Note: Do not change the file name, and do not copy any internal folder separately. This folder is set up exactly as needed to correctly be recognized and downloaded by the P80 consoles.**

---

*Figure 29: Software Download\_Flash Drive*

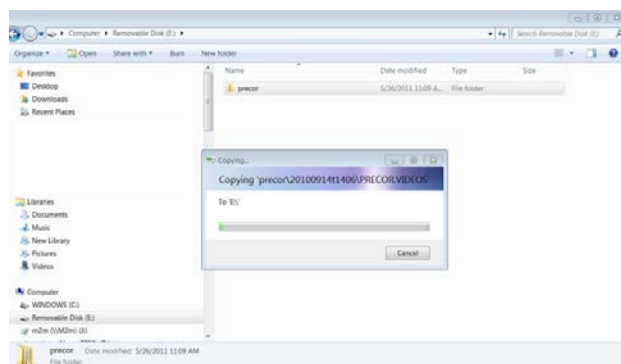

## Installing P80 software into the P80 console

---

**Note: The P80 stores two images of the software for the purpose of automatic error recovery. It is therefore strongly advised to perform the flash procedure twice in order to ensure that both images are the same software version. In addition, CPA, MFE, and GUI should be running on the same image.**

---

### Procedure

- 1 From the Welcome screen., press the Pause key and continue holding it down while you press in sequential order an X configuration on the Volume and Channel key pad (① Channel Up, ② Volume Down, ③ Volume Up, ④ Channel Down). Release the Pause key when done pressing the arrows.

---

**Note: The keypad X configuration sequence should be not faster than 1 second between each key stroke. Any speed faster than 1 second may result in an unsuccessful access to the sign-in screen.**

---

Figure 30: P80 Sign In Access

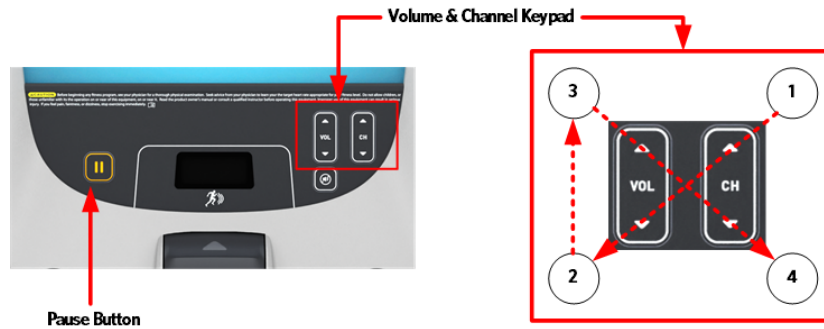

- 2 The sign-in screen will be displayed. Type in the technician access code (5,1,7,6,5,7,6,1) and press enter.
- 3 Press "Reflashing" to view and reflash the CPA, MFE, and GUI to image "A".

Figure 31: Settings to Reflashing Screen



**NOTE: All 3 (CPA, MFE, and GUI) must be rebooted to image "A", even if it is already on image "A". In addition these images must be rebooted in the specific order (First the CPA, then the MFE, and then the GUI).**

- a) From the "Reflashing" menu, press "CPA Reflashing"
- b) Press "Reboot to Slot A".

Figure 32: Settings to Reflashing to CPA Screen

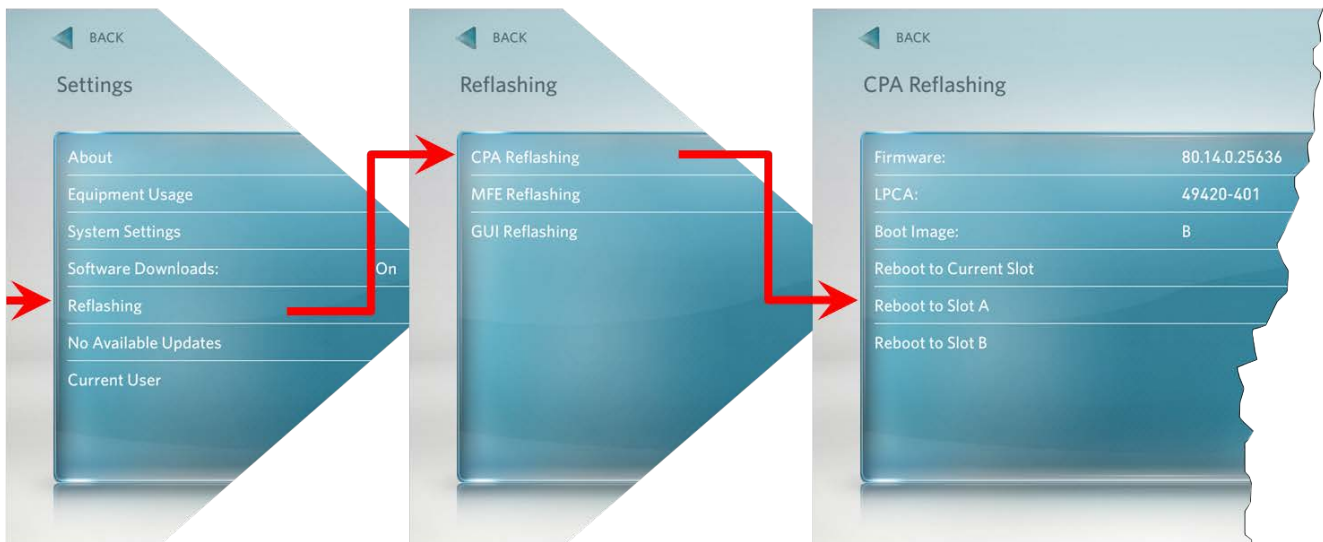

- c) Press "Restart CPA".

*Figure 33: Restart CPA Screen*

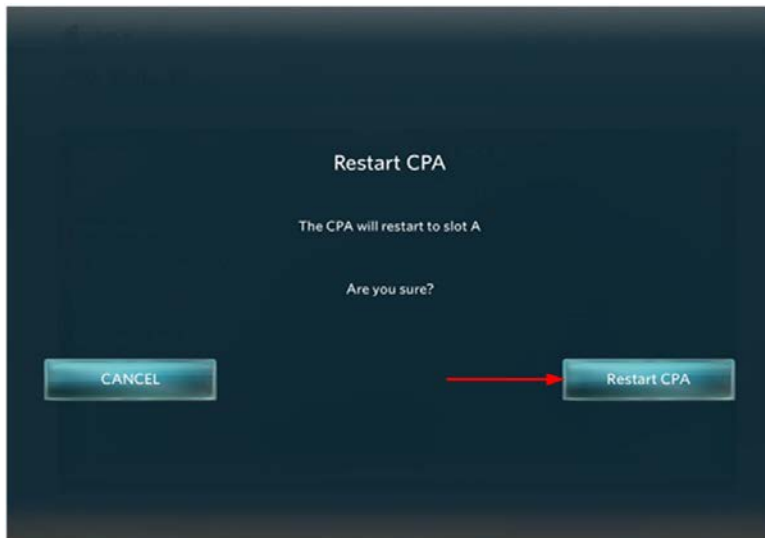

- d) Press **← BACK** to return to "Refashing".
- e) From the "Refashing" menu, press "MFE Reflashing".
- f) Press "Reboot to Slot A".

*Figure 34: Settings to Reflashing to MFE Screen*



- g) Press "Restart MFE".

Figure 35: Restart MFE Screen

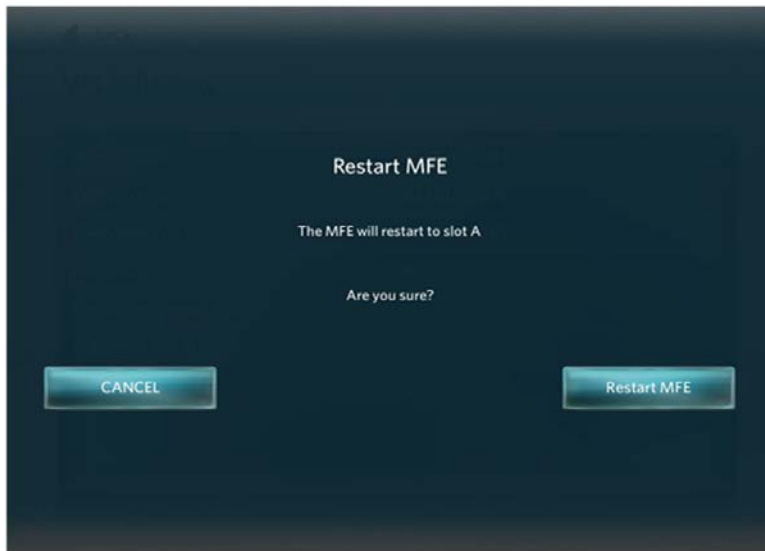

- h) Press **← BACK** to return to "Reflashing".
- i) From the "Reflashing" menu, press "GUI Reflashing".
- j) Press "Reboot to Slot A".

Figure 36: Settings to Reflashing to GUI Screen

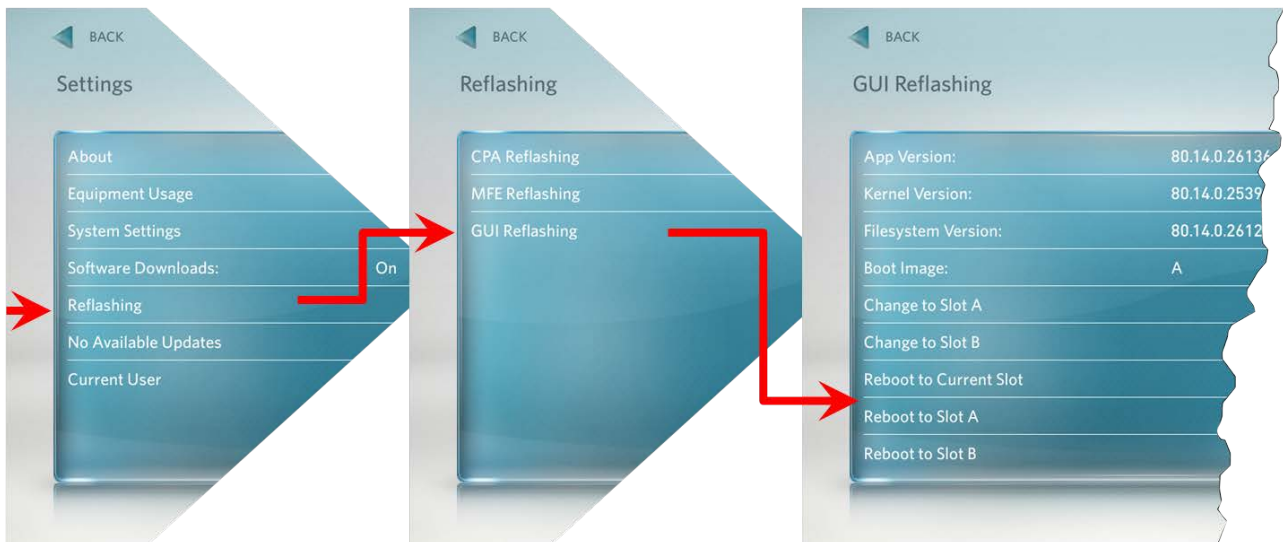

- k) Press "Restart GUI" and wait for the reboot to complete. The P80 will reboot to the "Welcome"Screen.

*Figure 37: Restart GUI Screen*



- 4 Re-enter diagnostics mode as described in step 1. Insert the USB Flash Drive into the USB Drive Port of the P80 console.

*Figure 38: USB Drive Port and P80 Settings Screen*



- 5 The P80 software will automatically access the USB Flash Drive files and look for a valid software update. While the USB Flash Drive is being validated, No Available Updates. Once an update file has been identified and validated, Available Updates will be displayed. Touch the spot on the P80 console screen where "Available Updates" is displayed to select.

- 6 A software package or list of software packages will be displayed on the P80 console screen. Touch the spot on the P80 console screen displaying the software package required.

---

***Note: PRECOR customer service will specify which software package is required when the service is requested to update P80 Console software. If you are unsure of which software package should be installed, contact PRECOR customer service.***

---

- 7 Touch Install and the P80 console will start the software installation process (this will take some time). Once the P80 finishes copying the files, a message on the screen will instruct you that it is safe to remove the USB Flash Drive device from the P80 USB port. The software installation process can take up to 45 minutes and the console will automatically reboot when it has finished.
- 8 Remove the USB Flash Drive from the P80 USB port **only when the screen indicates that it is safe to do so or at the "Welcome" screen.**
- 9 When the P80 has completed rebooting the Welcome screen will be displayed. The installation of the software update is now complete.
- 10 Verify the correct version of software has been installed. This can be found by touching the world icon in the upper left corner of the screen, the software version will be shown in the upper right hand corner, or by accessing the main menu using the instructions provided in steps 1 and 2, then selecting About. The software version will be displayed under Installed Bundle Version and should match the package selected in step 5.
- 11 It is recommended that the software be flashed twice to ensure best performance.
- 12 Repeat steps 4 through 10 to update the software on additional consoles.



# Section 7 - Display and Entertainment Settings

## P80 Display

The display settings allow you to configure Language, Measurement units, Standby Mode Delay, Time Zone, and Closed Captioning.

- 1 From the "**Settings**" menu, press "**System Settings**", and then press "**Display**". The "Display" menu will be displayed as below.

*Figure 39: Settings to System Settings to Display Screens*



- 2 To select a Display Setting, touch on an item in the Display menu, see the following **Display Settings Menu Table**.

*Figure 40: Display Screen*



## P80 Display Settings Menu Table

Settings	Settings Options	Factory Default	Configure/View/Test
<b>Language</b>	<ul style="list-style-type: none"> <li>◆ German</li> <li>◆ English</li> <li>◆ Spanish</li> <li>◆ French</li> <li>◆ Italian</li> <li>◆ Dutch</li> <li>◆ Russian</li> <li>◆ Japanese</li> </ul>	English	<ol style="list-style-type: none"> <li>1 Touch <b>Language</b></li> <li>2 Touch on a radio button next to the desired language, a dot will fill the radio button next to the selection.</li> <li>3 Touch <b>OK</b> to save the selection. Touch <b>CANCEL</b> to exit without saving the selection.</li> </ol> <p>Note: All menus and selection will be in the language selected.</p>
<b>Measurement Units</b>	US Standard or Metric	US Standard	<ol style="list-style-type: none"> <li>1 Touch <b>Measurement Units</b></li> <li>2 Touch on a radio button next to either US Standard or Metric; a dot will fill the radio button next to the selection.</li> <li>3 Touch <b>OK</b> to save the selection. Touch <b>CANCEL</b> to exit without saving the selection.</li> </ol>
<b>Standby Mode Delay</b>	<ul style="list-style-type: none"> <li>◆ 5 Minutes</li> <li>◆ 15 Minutes</li> <li>◆ 30 Minutes</li> <li>◆ 60 Minutes</li> </ul>	15 minutes	<ol style="list-style-type: none"> <li>1 Touch <b>Standby Mode Delay</b>.</li> <li>2 Touch on a radio button next to the desired delay time, a dot will then fill the radio button.</li> <li>3 Touch <b>OK</b> to save the selection. Touch <b>CANCEL</b> to exit without saving the selection.</li> </ol>
<b>Time Zone</b>  <i>Note: This setting will be displayed only on software version 3.0 or earlier.</i>	GMT- 12 through GMT + 12	GMT - 00-10	<ol style="list-style-type: none"> <li>1 Touch <b>Time Zone</b>.</li> <li>2 Touch on the radio button next to the desired Time Zone, a dot will fill the radio button.</li> <li>3 Touch <b>OK</b> to save the selection. Touch <b>CANCEL</b> to exit without saving the selection.</li> </ol>

Settings	Settings Options	Factory Default	Configure/View/Test
<b>Internet Browser Access</b>	ON/OFF	OFF	<ol style="list-style-type: none"> <li>1 Touch <b>Internet Browser Access</b>.</li> <li>2 Touch on the radio button next to the ON, a dot will fill the radio button.</li> <li>3 Touch <b>OK</b> to save the selection. Touch <b>CANCEL</b> to exit without saving the selection.</li> </ol>
<b>Preva® Net Panel</b>	ON/OFF	ON	<ol style="list-style-type: none"> <li>1 Touch <b>Preva® Net Panel</b>.</li> <li>2 Touch on the radio button next to the ON or OFF, a dot will fill the radio button.</li> <li>3 Touch <b>OK</b> to save the selection. Touch <b>CANCEL</b> to exit without saving the selection.</li> </ol>

4 Touch  **BACK** to exit "Display" (back to "System Settings" menu).

## P80 TV Settings

The TV settings allow you to Scan Channels and configure the TV Source, Region, Default Channel, and Channel Names.

- 1 From the "**Settings**" menu, press "**System Settings**", and then press "**TV Settings**". The "TV Settings" menu will be displayed as below.

*Figure 41: Settings to System Settings to TV Settings Screens*



- 2 To select a TV Settings setting, touch on an item in the TV Settings menu, see the following **TV Settings Menu Table**.

*Figure 42: TV Settings Screen*



## P80 TV Settings Menu Table

Settings	Settings Options	Factory Default	Configure/View/Test
<b>Channel Guide</b>	Scan Channels		<ol style="list-style-type: none"> <li>1 Touch <b>Scan Channels</b>.</li> <li>2 Scan will take approximately 30 minutes</li> </ol>
<b>Region</b>	Select the appropriate region for your location.	United States	<ol style="list-style-type: none"> <li>1 Touch <b>Region</b>.</li> <li>2 Select from the list.</li> <li>3 Touch <b>OK</b> to save the selection. Touch <b>CANCEL</b> to exit without saving the selection..</li> </ol>
<b>Volume Correction</b>	5db to -5db	0db	<ol style="list-style-type: none"> <li>1 Touch <b>Volume Correction</b>.</li> <li>2 Adjusted the  arrows to the desired db volume correction.</li> <li>3 Touch <b>OK</b> to save the selection. Touch <b>CANCEL</b> to exit without saving the selection.</li> </ol>
<b>Default Channel</b>	Set a default channel for the equipment. This is the channel that will display when the TV is turned on.		<ol style="list-style-type: none"> <li>1 Touch <b>Default Channel</b>.</li> <li>2 Select from the list.</li> <li>3 Touch <b>OK</b> to save the selection. Touch <b>CANCEL</b> to exit without saving the selection.</li> </ol>
<b>Skip Unnamed Channels</b>	ON/OFF	ON	<p>Touch <b>OFF</b> to disable this function.</p> <p><b>Note: Scans for digital channels will add addition time to scan.</b></p>
<b>Closed Captioning</b>	ON/OFF	ON	<ol style="list-style-type: none"> <li>1 Touch <b>Closed Captioning</b></li> <li>2 Touch on a radio button next to either <b>ON/OFF</b>, a dot will fill the radio button next to the desired selection.</li> <li>3 Touch <b>OK</b> to save the selection. Touch <b>CANCEL</b> to exit without</li> </ol>

<b>Settings</b>	<b>Settings Options</b>	<b>Factory Default</b>	<b>Configure/View/Test</b>
			saving the selection.
<b>Extensive Scan</b>	ON/OFF	OFF	<p>Touch <b>ON</b> to enable this feature.</p> <p>Scans for analog channels across multiple frequencies. The scan may take up to 2 hours.</p>
<p><b>Export/Import Channel Names</b> (software prior to 3.2)</p> <p><b>Export/Import Channel Names</b> (software 3.2 or later)</p>			<p>Export Channels names to a USB drive, edit names with a PC. Save the edited names back to USB drive and then import them into the P80.</p> <p>Export Channels to a USB drive, edit names with the Precor Channel Editor. Save the edited names back to USB drive and then import them into the P80.</p>

## Channel Guide

The following procedure discusses how to set up the channel guide and how to configure audio and video playback.

Note: The correct region must be set before you scan for available channels. To confirm the settings, touch Region. A list of regions will be displayed. Confirm that the radio button next to the appropriate region for your area is selected. If the highlighted region is incorrect, touch on the radio button next to appropriate region. Touch OK and then touch BACK to go to the TV Settings menu.

### To scan for available channels:

- 1 Touch Channel Guide from the TV Settings menu.
- 2 Select "Delete All" twice.
- 3 Touch "Channel Guide".
- 4 Touch **Scan Channels**.

The console will scan for available channels and when the scan is finished all available channels will be displayed on the screen (this will take some time).

### To name a channel:

There are 3 methods for naming the channels:

- ◆ Direct entry from the P80.
- ◆ Computer method for P80 consoles running software prior to version 3.2.
- ◆ Computer method for P80 consoles running software version 3.2 or later.

### Direct entry from the P80 screen

- 1 Touch a channel from the channel guide list.
- 2 Touch Channel Name. A keyboard will be displayed.
- 3 Type in the desired channel name.
- 4 Touch OK.
- 5 Touch the next channel from the channel guide list and repeat steps 1 through 4 until all channels are named.



## Computer method for P80 consoles running software prior to version 3.2

- 1 Navigate to the "TV settings" menu, as described at the beginning of this "Entertainment Settings" Section.
- 2 Insert a USB thumb drive into the external USB port located on the top left hand corner of the P80 front panel, just above the screen. Touch "Import/Export Channel Names from the "TV Settings" menu.
- 3 Touch "Export" from the P80 screen, and wait for the message indicating that the export is complete.
- 4 Touch **← BACK** several times to exit to the "Welcome" screen, and remove the USB thumb drive from the P80 USB port.
- 5 Insert the USB thumb drive into a USB port on any Windows based PC, and choose to view the file contents of the thumb drive.
- 6 Open the "Precor" folder, and locate the file called "channel-list.ini". Right click on the channel list file and select "OPEN WITH" and choose "WordPad" (do not open the file in "Word" or "notepad").

Figure 43: Channel-List\_Precor Folder

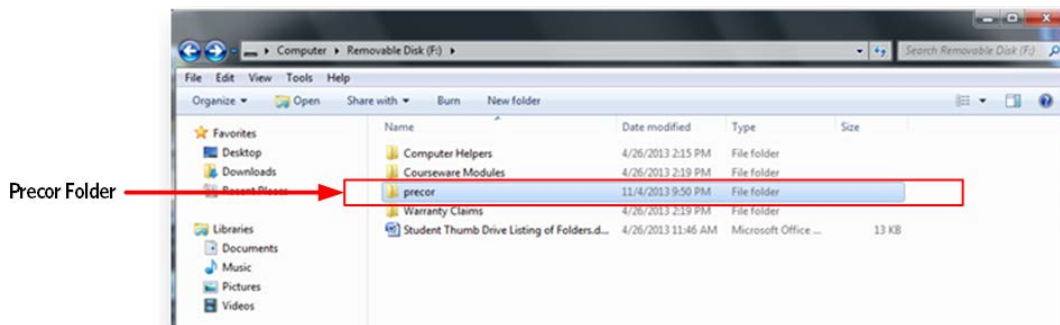
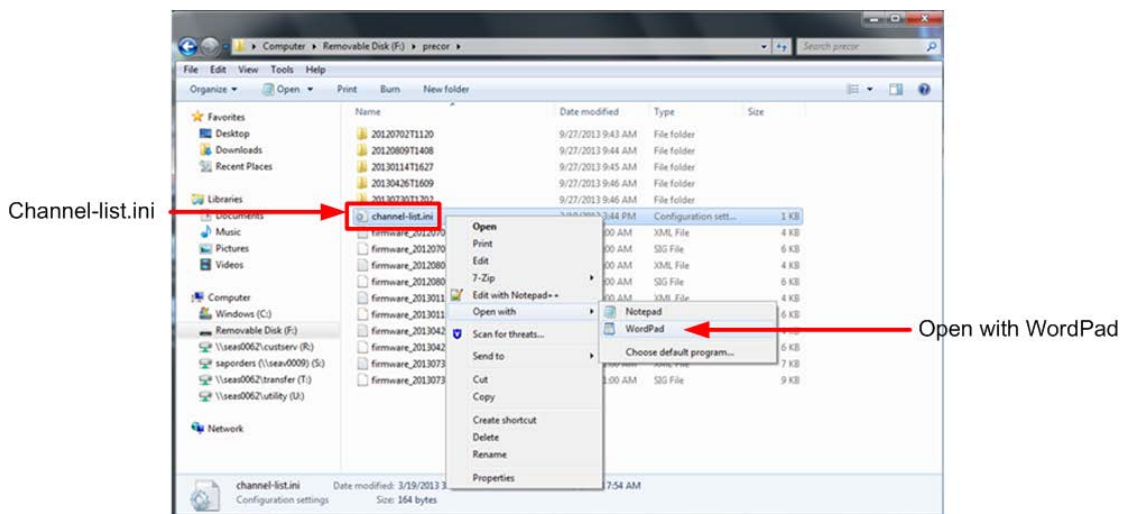
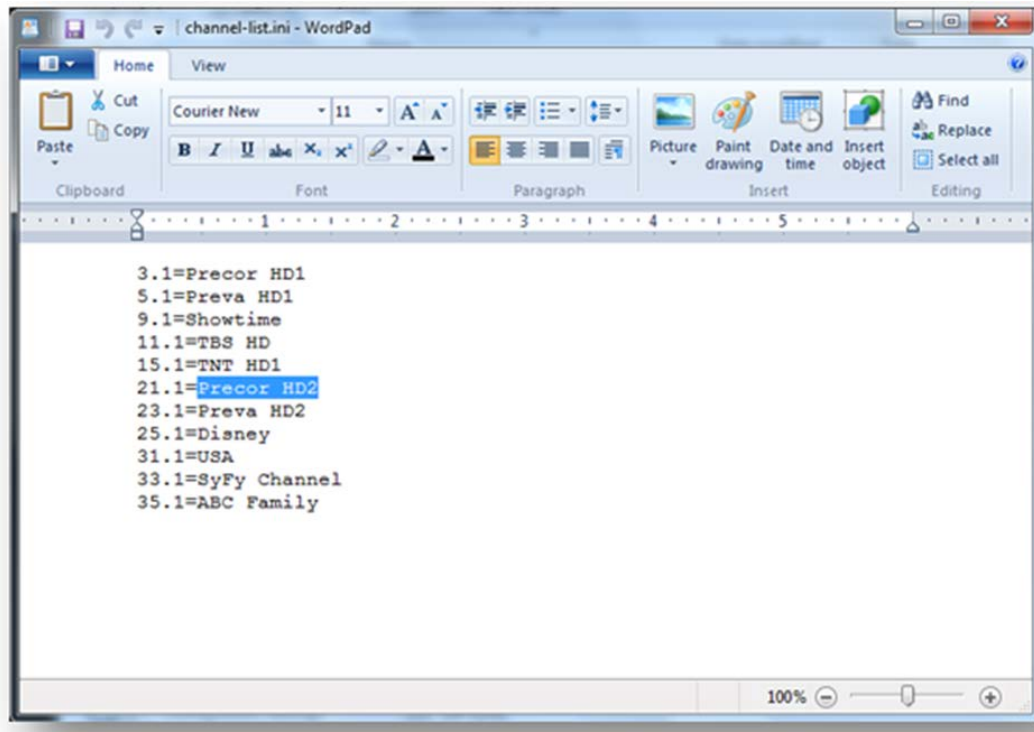

Figure 44: Channel-List\_File\_WordPad



- 7 You should see 2 columns of channel information. The first column should be the channel numbers, and the second column should be channel names, but un-named channels will be displayed as the channel number. Highlight the channel number in the channel name column and enter the channel name. Repeat this step for all un-named channels.
- 8 Save As the .ini file onto the USB thumb drive.

*Figure 45: WordPad List*



- 9 In the "MY COMPUTER" window, locate the removable drive that represents the USB thumb drive, right click on it and select "Eject". When the computer displays "safe to remove hardware" remove the USB thumb drive.
- 10 Insert the USB thumb drive into the P80 USB port, navigate back to the "TV Settings" menu, and select "Import/Export Channel Names".
- 11 Touch "Import" from the P80 screen, and wait for the message indicating that the import is complete.
- 12 The channels will now be named.

### **Computer method for P80 consoles running software version 3.2 or later**

- 1 Navigate to the "TV settings" menu, as described at the beginning of this "Entertainment Settings" Section.
- 2 Insert a USB thumb drive into the external USB port located on the top left hand corner of the P80 front panel, just above the screen. Touch "Import/Export Channel Names" from the "TV Settings" menu.

- 3 Touch "Export" from the P80 screen, and wait for the message indicating that the export is complete.
- 4 Touch **← BACK** several times to exit to the "Welcome" screen, and remove the USB thumb drive from the P80 USB port.
- 5 Install "Precor Channel Editor 1.0" on your computer if you have not already done so.
- 6 Insert the USB thumb drive into a USB port on any Windows based PC.
- 7 Open the "Precor Channel Editor 1.0".
- 8 Click on the "Open" button at the top of the program screen, and from the "Precor" folder select the file called channel-guide.json. The channel list will appear in the channel editor window as shown below.

*Figure 46: Channel Editor\_Open Button*

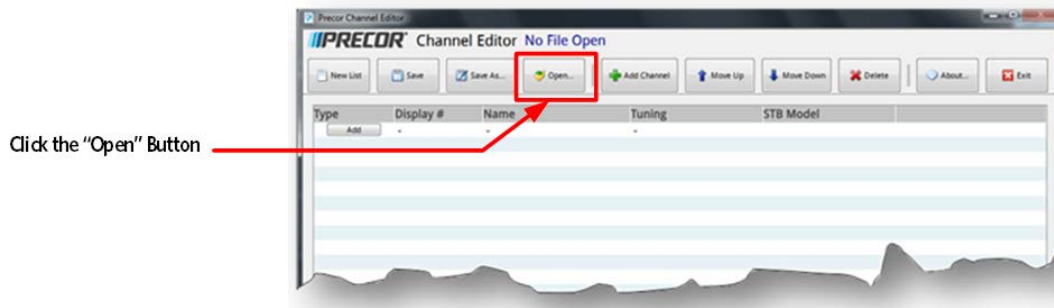

- 9 The channel names will be in the "Name" column (un-named channels will show as the channel number). Click on the "Name" column at the end of the name (channel number) that you want to change. The editor does not allow you to highlight the name, so you will have to use backspace to delete the current name (which will be a number on un-named channels) and type in the new name. Repeat this step for all unnamed channels.

Figure 47: Channel Editor List

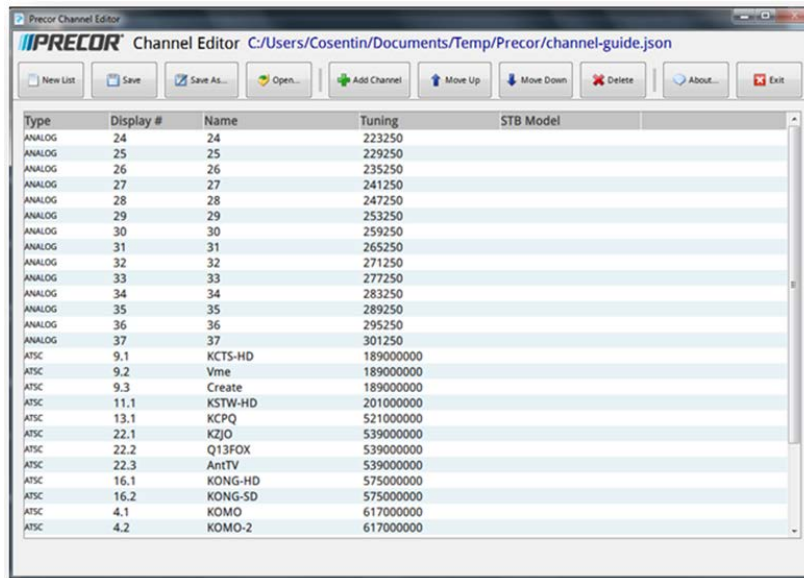

- 10 Once all the un-named channels have been named, Click the "Save" button at the top of the program window, and click on the "Exit" button to close the Precor Channel Editor program.
- 11 In the "MY COMPUTER" window, locate the removable drive that represents the USB thumb drive, right click on it and select "Eject". When the computer says "safe to remove hardware" remove the USB thumb drive.
- 12 Insert the USB thumb drive into the P80 USB port, navigate back to the "TV Settings" menu, and select "Import/Export Channel Names".
- 13 Touch "Import" from the P80 screen, and wait for the message indicating that the import is complete.

**To delete a channel from the Channel Guide:**

- 1 On the Channel Guide screen, touch the listing for the channel you want to delete.
- 2 Touch the **DELETE** button.
- 3 When asked, Are you sure? Verify that you want to proceed, and then touch YES.
- 4 Touch **← BACK** to Settings.

**How to update the channel plan:**

- 1 Delete old channel- rescan- then reboot.





# Section 8 - Cloning Settings

## P80 Manage Settings (Cloning)

*The only P80 console settings that can be imported and exported through a USB Flash Drive device are:*

**P80 Manage Settings Table**

Menu	Settings
<b>Display</b>	<ul style="list-style-type: none"> <li>◆ Measurement of Units</li> <li>◆ Standby Mode Delay</li> <li>◆ Time Zone</li> <li>◆ Closed Captioning</li> <li>◆ Language</li> </ul>
<b>Workout Limits</b>	<ul style="list-style-type: none"> <li>◆ Maximum Workout Duration</li> <li>◆ Maximum Pause Time</li> <li>◆ Summary Time Out</li> <li>◆ Resistance Range (RBK, UBK only)</li> <li>◆ Speed Limit (TRM only)</li> <li>◆ Incline Limit (TRM only)</li> <li>◆ Auto Stop (TRM only)</li> <li>◆ Cross Ramp Auto Level (EFX only)</li> </ul>
<b>TV Settings</b>	<ul style="list-style-type: none"> <li>◆ Channel Guide</li> <li>◆ Region</li> <li>◆ Default Channel</li> <li>◆ Skip Unnamed Channels</li> </ul>

<b>Menu</b>	<b>Settings</b>
<b>Network Settings</b>	<ul style="list-style-type: none"> <li>◆ Primary DNS - Manual only</li> <li>◆ Secondary DNS - Manual only</li> <li>◆ Gateway - Manual only</li> <li>◆ Netmask - Manual only</li> </ul>
<b>Connectivity</b>	<ul style="list-style-type: none"> <li>◆ Network Type</li> <li>◆ Preva® Server Address</li> </ul>



## P80 Cloning Procedure

The following procedure will explain how to save existing P80 console settings onto a USB Flash Drive and then import the saved settings into another P80 console.

---

**Note: Settings from one P80 console will need to be configured manually and imported to a flash drive device before cloning and exporting to additional P80 consoles.**

---

- 1 From the Welcome screen., press the Pause key and continue holding it down while you press in sequential order an X configuration on the Volume and Channel key pad (① Channel Up, ② Volume Down, ③ Volume Up, ④ Channel Down). Release the Pause key when done pressing the arrows.

Figure 48: P80 Sign In Access

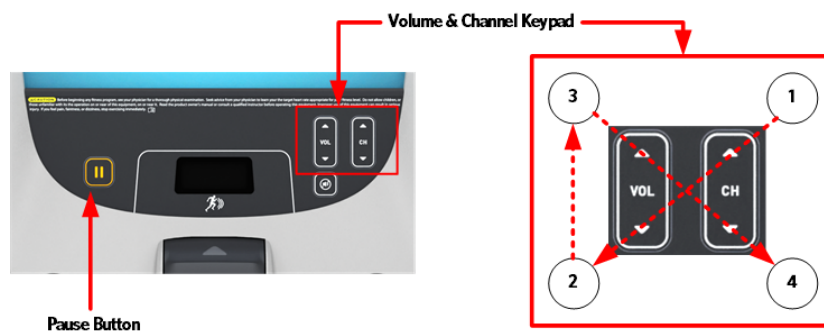

- 2 The sign-in screen will be displayed. Type in the technician access code (5,1,7,6,5,7,6,1) and press enter. The Settings menu will be displayed. See Settings Table.
- 3 Use the System mode to configure settings in ways that benefit the users and the facility. Changes made to these settings save to the fitness equipment. To select a Setting touch on an item in the Settings menu.
- 4 The Settings screen will be displayed. Select **Systems Settings** from the Settings menu.
- 5 From the Systems Settings menu select Manage Settings.

*Figure 49: Settings to System Settings to Manage Settings Screens*



- 6 The Manage Settings screen will display two gray inactive USB Flash Drive Icons.
- 7 Insert the USB Flash Drive into the USB Drive Port of the P80 console.

*Figure 50: P80 USB Flash Drive Port*



- 8 When the gray inactive Save to USB Flash Drive Icon becomes active and lights up, select Export to USB.

---

***Note: Depending on the type of Flash Drive device used, it may take up to a minute for the USB Flash Drive Icons to become active (light up) after the USB Flash Drive device has been inserted into the P80 console.***

---

*Figure 51: Cloning Procedure- Save To USB*



- 9 You will see a process bar and then Settings exported successfully to the USB drive displayed.
- 10 When the export operation is complete, Touch **OK** to return the Settings menus.

*Figure 52: Settings Exported Successfully*



- 11 The settings export is now complete and you can exit the service mode by touching the back arrow until you get to the Welcome screen. Remove the USB Flash Drive only after the P80 is at the Welcome screen.
- 12 Move the USB Flash Drive device with the saved settings to a P80 console that you would like to import the saved settings to.

- 13 Access the Manage Settings screen by following the described steps 1 through 6.
- 14 Insert the USB Flash Drive into the USB Drive Port of the P80 console.
- 15 Wait for the USB Flash Drive Icons to become active (light up) and then select Import from USB.

*Figure 53: Manage Settings - Import*

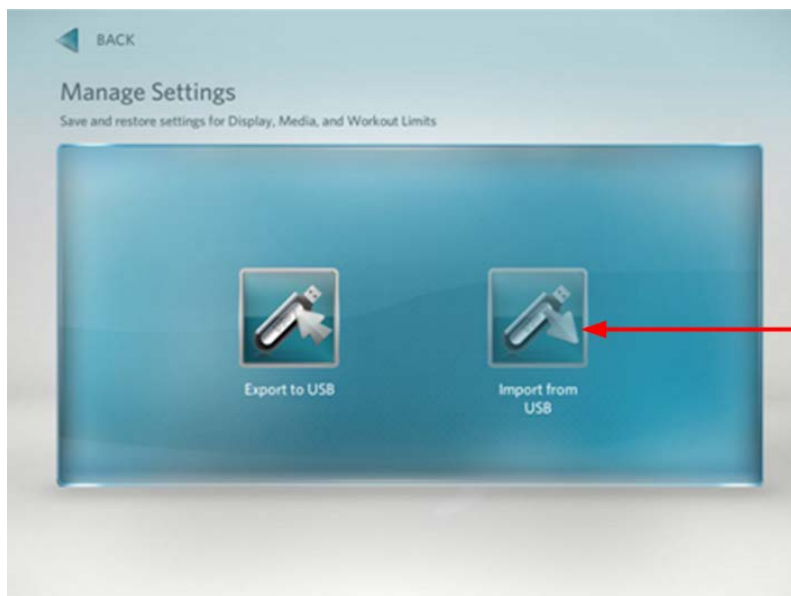

- 16 You will see a process bar and then Settings imported successfully displayed.

*Figure 54: Settings Imported Successfully*



- 17 Touch OK to return the Settings menus.

18 Exit the service mode as described in steps 11.

19 Repeat the described process steps 12 through 16 for any remaining P80 consoles.



# Section 9 - Connectivity and Registration

## P80 Connectivity

Precor strongly recommends that only a qualified/trained service provider set up and register the P80.

These settings provide the following information:

- ◆ Network Type
- ◆ Configuration
- ◆ Status
- ◆ IP Address
- ◆ Preva® Server

### To view connectivity information:

- 1 From the "Settings" menu, press "System Settings", and then press "Connectivity". The "Connectivity" menu will be displayed as below.

*Figure 55: Settings to System Settings to Connectivity Screens*



- 2 To select Connectivity Setting touch on an item in the Connectivity Settings menu.

## P80 Connectivity Settings Menu Table

Settings	Factory Default	Detail
<b>Network Type</b>	Wired	Wireless connectivity not supported at this time.
<b>Configuration</b>	Automatic	<p>Automatic (DHCP) or Manual (Static IP)</p> <p>Precor Recommends Automatic Configuration unless very specific customer needs require a manual configuration.</p> <p>Press Network Settings to view the:</p> <ul style="list-style-type: none"> <li>◆ IP Address</li> <li>◆ Netmask</li> <li>◆ Gateway</li> <li>◆ DNS Primary</li> <li>◆ DNS Secondary</li> </ul>
<b>Status</b>		<p>Connected –Connected to the network.</p> <p>Not Connected - Not connected to the network</p>
<b>IP Address</b>		Location-specific
<b>Preva® Server</b>		na.preva.com



## P80 Connectivity Set Up and Registration Procedure

- 1 Before you attempt to connect to the Precor Preva® Server, check the status field and ensure that "Connected" is displayed on the "Status" line. If the Status field shows Not Connected, you will need to diagnose your networking issue. Continue with Step 2. If the Status Field shows Connected go to step 3.
- 2 Either the Ethernet cable is not connected or there is a problem with the network connection. Check the connection and then check the Status field again. If the Status field shows Connected continue with step 3. If the Status field still shows Not Connected contact your IT expert.

*Figure 56: Not Connected & Connected*

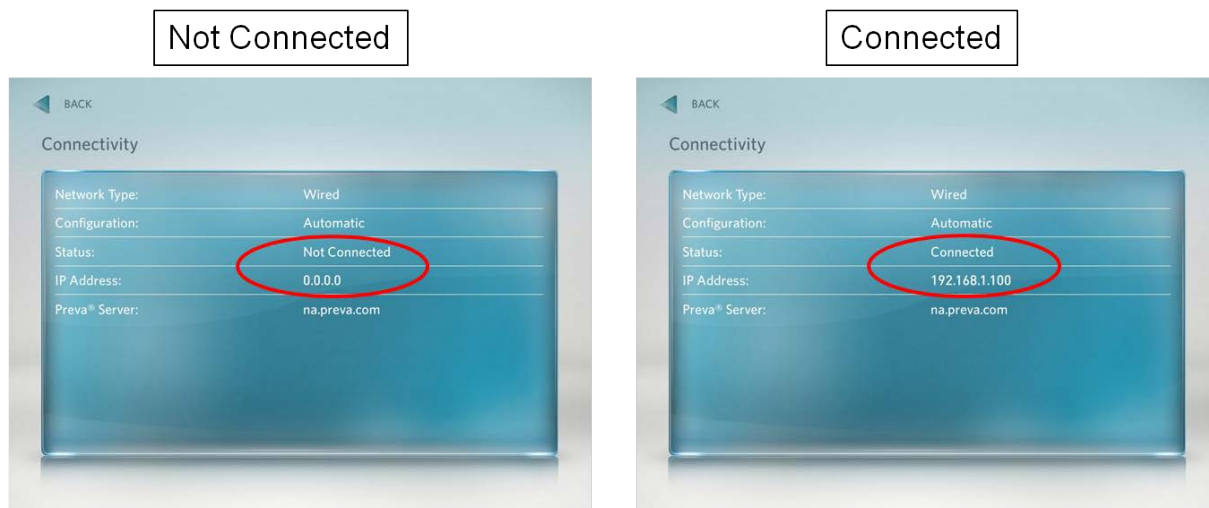

- 3 Check the IP Address field for a valid IP Address. If the IP Address is present continue with step 12. If the IP Address is "all zeros" continue with step 4.

*Figure 57: IP Address Connected*



- 4 If the Status shows Connected and the IP Address is "all zeros", it will be necessary to either have the P80 software assist in acquiring the IP Address (Recommended) or enter the IP address manually. Touch Configuration from the Connectivity menu.
- 5 Touch on the radio button next to Automatic, and then touch **SETTINGS**.

*Figure 58: Connectivity Automatic Screen*



- 6 The P80 will attempt to connect to the network, and when successful will acquire the networking information necessary for registration. If the console was already connected, it will skip straight to the 'Network Settings' screen and display the current network information. Once a good IP Address has been acquired, the P80 can now be registered. Continue with step 12.

---

***Note: Automatic configuration will make up the vast majority of all installations. If the installation requires a manual configuration, you will be notified as such within the installation paperwork. If a manual configuration is indicated, precede with steps 7 - 11 only with assistance from the facilities IT personnel.***

---

### **Manual Configuration Steps Only:**

- 7 Touch **CONFIGURATION** from the **Connectivity** menu.
- 8 Touch on radio button next to **Manual**, and then touch **SETTINGS**.

*Figure 59: Connectivity Manual*



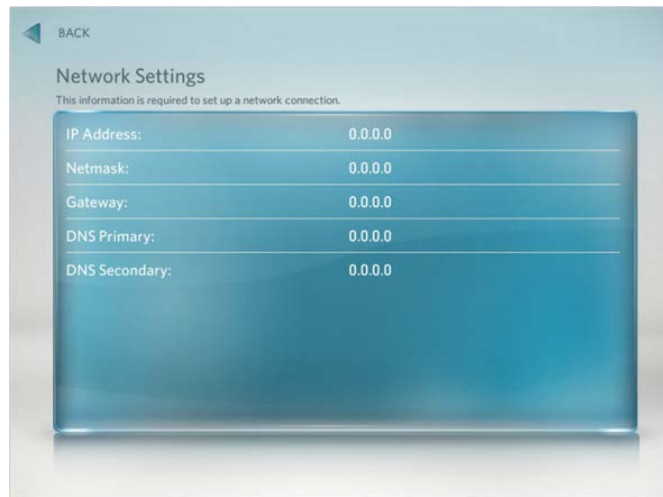

- 9 Touch one of the network settings items from the Connectivity menu.
- 10 Enter the data acquired from the network administrator using the on-screen key pad, and then select OK (IP Address, Netmask, Gateway, DNS Primary, DNS Secondary).
- 11 Repeat steps 9 and 10 for the remaining network settings.

*Figure 60: Network Settings - Data Screen*



- 12 Once a good IP Address is displayed, touch Preva® Server (from the "Connectivity" menu) to enter the web address.
- 13 Enter na.preva.com by using the on-screen key pad.
- 14 Touch **OK**.

- 15 A screen will appear stating that the equipment is ready to be set up, touch **USER NAME AND PASSWORD**.
- 16 The user name and password will have been provided by Precor prior to installation. Enter the user name using the on-screen keypad, then touch **NEXT**.
- 17 Enter the password using the on-screen keypad, then touch **NEXT**.
- 18 The next screen will list information that you need to know before continuing with the registration process.
  - Site Code - This is given at the time of the dispatch.
  - Base Serial Number - The base serial number is located on the exercise equipment.
  - Friendly Name - It is recommended that you have a list of the equipment with friendly names already assigned, such as Elliptical 1, Treadmill 22, and so forth. Touch **NEXT**.
- 19 Enter the Site Code using the on-screen keypad, then touch **NEXT**.
- 20 Enter the Base Serial Number using the on-screen keypad, then touch **NEXT**.
- 21 Enter the Friendly Name using the on-screen keypad, then touch **NEXT**.
- 22 The next screen displayed will be the Registration Summary screen. Review the screen to ensure the information entered is correct before completing the registration. If the information is not correct touch  **BACK** until the screen with incorrect information is displayed. Make the corrections and then touch **NEXT** until you are back at the Registration Summary Screen.
- 23 Touch **Register** to submit the data.
- 24 If the registration was successful a screen with current software version will be displayed. Touch **FINISH** to the Systems Settings menu, if a newer software version is available, the console will automatically start the download.
- 25 Touch  **BACK** to Exit.

---

# Troubleshooting Procedures

---

## In This Section

Verifying the Hardware Version.....	83
Boot Error resulting in Yellow Triangle Being Displayed .....	85
Boot Error resulting in Red Triangle Being Displayed .....	86
Preva Net Panel Icon Not Displayed .....	87
Preva Net Panel Displayed but Web Pages and/or RSS Feeds Do Not Load.....	88
Sign-in Button Does Not Appear On the Welcome Screen .....	89
Black Screen - Full Console.....	90
Poor Quality Video - Single Unit Only .....	91
Poor Quality Video - All Units .....	92
Poor Quality Video - One Channel(s) or Limited Channels .....	93
Green Screen .....	94
Stuttering Channels .....	95
Touch Screen Slow Response .....	96
Touch Screen Responds Incorrectly to Touch or is Unresponsive.....	97
Poor Quality Video - One Channel or Limited Channels .....	98
Poor Audio Quality - All Channels, Multiple Units .....	99
Machine Controls Unresponsive.....	100
Message Out of Service Displayed.....	101
Message Please Reset the Treadmill Displayed .....	102
Unit reboots of its own volition.....	103
Treadmill - Resets to Welcome Screen at Beginning of the "3...2...1..." Countdown.....	104
USB Flash Drive Not Recognized.....	105

## Verifying the Hardware Version

Since the initial release of the P80 there have been updates in hardware as well as software. Before you begin to troubleshoot, it may be necessary to verify what hardware version is installed. There are 2 methods of determining the hardware version:

**Method 1 - The Event Log:**

Reboot the P80. Once the P80 fully boots to the "Welcome" screen, go into the service access menus and press "ABOUT", then press "EVENT LOG". Look for an entry that begins with "OMAP" and look for the word "Hardware"

- ◆ Hardware1 = 256K memory (early P80s)
- ◆ Hardware2 = 512K memory
- ◆ Hardware3 = includes new dual power supply

**Method 2 - Part Number Dash**

On the back of the P80 armor behind the vent cover; look for the part number label.

- ◆ Part number with -101 or -601 only = 256K memory (early P80s)
- ◆ Part number with -102 or -602 = 512K memory
- ◆ Part number with -103 or -603 only = includes new dual power supply

## Boot Error resulting in Yellow Triangle Being Displayed

### Description

When the P80 is powered on there is a small delay of 2.5 minutes caused by the various boards initializing in a specific sequence. If there is a problem with the initialization of any of these, the P80 will attempt to load that software from the backup software location. While the backup software is loading a progress bar will be displayed, but if the attempt fails a red "X" will be displayed over the progress bar, and a 2nd attempt will be made automatically. If it fails the second attempt, the yellow triangle screen will be displayed.

*Figure 61: Yellow Triangle Screen*



### Possible Causes

- 1 Second re-boot attempt failed resulting in a recoverable boot error.

### Possible Remedies

- 1 Recovery from this error may be possible. Please call Precor Customer Support for assistance.

## Boot Error resulting in Red Triangle Being Displayed

### Description

When the P80 is powered on there is a small delay of 2.5 minutes caused by the various boards initializing in a specific sequence. If there is a problem with the initialization of any of these, the P80 will attempt to load that software from the backup software location. While the backup software is loading a progress bar will be displayed, but if the attempt fails a red "X" will be displayed over the progress bar, and a 2nd attempt will be made automatically. If it fails the second attempt, and the error is non-recoverable, the red triangle screen will be displayed.

*Figure 62: Red Triangle Screen*



### Possible Causes

- 1 Second re-boot attempt failed resulting in a non-recoverable boot error.

### Possible Remedies

- 1 Recovery from this error **is not** possible. Replace the P80 console.



## Preva Net Panel Icon Not Displayed

### Description

Preva® functions such as the user login button, Preva® Net Panel Icon, and Preva® Net Panel are not being displayed.

### Possible Causes

- 1 Preva® Net Panel not enabled in system settings.
- 2 There is no network connection to the console.
- 3 Console did not acquire a valid IP address.
- 4 Insufficient Tier rights in Preva® Business Suite

### Possible Remedies

- 1 Go to "System Settings", Press "Display", and toggle the Preva® Net Panel setting to "ON"
- 2 Check for bad and/or missing Ethernet cables or connectors. Disconnect the Ethernet cable feeding the unit, and plug it into the Ethernet port of a laptop or netbook computer. Verify that the computer's Ethernet LEDs flicker, and that the computer can access a web page using the web browser.
- 3 Go to "System Settings", press "Connection" and verify the correct configuration (Automatic or Manual), change if necessary and press "OK".
- 4 Contact Precor for Preva® account activation or assistance.

# Preva Net Panel Displayed but Web Pages and/or RSS Feeds Do Not Load

## Description

Preva® functions such as the user login button, Preva® Net Panel Icon and Preva® Net Panel are displayed, but either the word "WEB" is not displayed on the Preva® Net Panel list and/or the RSS feed and web pages do not load.

## Possible Causes

- 1 Web Browser is not enabled in system settings.
- 2 There is no network connection to the console.
- 3 Console did not acquire a valid IP address.
- 4 Insufficient Tier rights in Preva® Business Suite

## Possible Remedies

- 1 Go to system settings and toggle the Web Browser setting to "ON"
- 2 Check for bad and/or missing Ethernet cables or connectors. Disconnect the Ethernet cable feeding the unit, and plug it into the Ethernet port of a laptop or netbook computer. Verify that the computer's Ethernet LEDs flicker, and that the computer can access a web page using the web browser.
- 3 Go to "System Settings/Connection" and verify the correct configuration (Automatic or Manual), change if necessary and press "OK".
- 4 Contact Precor for Preva® account activation or assistance.

## Sign-in Button Does Not Appear On the Welcome Screen

### Description

The "Welcome" screen displays a "Workouts" button on the bottom left side of the screen, and a "Quickstart" button on the bottom right side of the screen. The "Sign-in" button should be at the bottom center of the screen.

### Possible Causes

- 1 Upgrade software to version 3.0 or higher.

### Possible Remedies

- 1 Contact Precor for Preva® account activation or assistance.

## Black Screen - Full Console

### Description

Console displays only a black screen. Machine is unusable.

### Possible Causes

- 1 Console has frozen
- 2 Console is attempting to boot to an image that has corrupted
- 3 Touch screen has failed

### Possible Remedies

- 1 Reboot the machine to resolve any software freezing issues.
- 2 If the console is attempting to boot to a corrupted software image, when a reboot is performed, the CPA version number will scroll across the display of the machine controls, but the screen will remain black and will never reach the Precor splash screen. Perform a 4 Power Cycle (See Boot Screen Procedure below) to force the machine to revert to the backup image. When the unit boots successfully, reflash the unit with the correct software to ensure that the old, corrupted image has a usable image installed.
- 3 If the touch screen has failed, the entire console will need to be replaced.

### Boot Screen Procedure

- 1 Turn the power off, wait 5-10 seconds, then back on. On treadmills, turn the on/off switch to the off position then back to the on position. On self powered units, disconnect the power source connected to the P80 console and then reconnect the power source.
- 2 Wait 5-15 seconds. Watch for the screen to flash. It is critical that the timing be no less than 5 seconds and no greater than 45 seconds for the procedure to be successful.
- 3 **Repeat steps 1 and 2 for 3 additional power Off and On cycles.**
- 4 On the last or 4<sup>th</sup> cycle leave the power connected or the power switch turned to the On position allowing the P80 console to boot up completely.
- 5 If the P80 console boot up to the Welcome screen was successful, go to step 6. If the P80 console still will not boot to the Welcome screen try the power cycle again up to two times more as needed. Contact PRECOR customer support.
- 6 Reprogram the P80 console with the most current software package available. P80 Updating Software, for instructions on how to reprogram the P80 console. Be sure to double flash.

## Poor Quality Video - Single Unit Only

### Description

Television signal is present, but picture quality is consistently or inconsistently poor across all available channels.

### Possible Causes

- 1 Loose or damaged coaxial cable
- 2 Poor television signal to the machine
- 3 Incorrect region setting in channel settings

### Possible Remedies

- 1 Check for good video signal to the tuner.
- 2 Inspect jumper cable connecting fitness equipment to the video drop. If it is visibly damaged or disconnected, replace or reconnect. If it passes visual inspection, swap with a known good jumper cable. If a TV channel now appears, the cable is the cause. Replace the jumper cable. If the channel does not appear, perform the same check on the F connectors.
- 3 Inspect the cable that runs from the patch panel at the bottom of the machine to the console. If this is disconnected or damaged, reconnect or replace. If the cable passes visual inspection, use a known good cable to bypass this cable. If the TV channel appears, replace the coax cable running through the machine.
- 4 Connect the machine to a known good A/V drop. If the TV channel now appears on the console, verify the drop is good. If not, have the customer contact their A/V service technician to repair the drop.
- 5 Verify signal strength with signal meter.
- 6 As above, verify condition and connections of coax cables as well as verify quality of signal to that drop. Verify signal strength with signal meter.
- 7 Enter the Settings Menu. Select System Settings, then TV Settings. Verify that unit is set for United States.

## Poor Quality Video - All Units

### Description

Television signal is present, but picture quality is consistently or inconsistently poor across all available channels.

### Possible Causes

- 1 Loose or damaged coaxial cable at or near head end.
- 2 Poor television signal from head end.
- 3 Poor television signal to club.
- 4 All machines were configured using incorrect region setting.

### Possible Remedies

- 1 Verify condition and connections of video distribution network. Begin as close to head end as possible and check for visible damage to coaxial cables or connectors. Verify all connections are tight.
- 2 Check signal quality and strength as close to head end as possible. If poor from the head end have customer contact their A/V service company to ensure signal from head end is within acceptable parameters.
- 3 Troubleshoot as above. Signal provider (e.g. Cable Company, Satellite Company, etc.) will need to address this issue.
- 4 Enter the Settings Menu. Select System Settings, then TV Settings. Verify that unit is set for United States.. See Procedure TV Settings.

## Poor Quality Video – One Channel(s) or Limited Channels

### Description

One or a limited number channels on a unit has poor reception or no reception.

### Possible Causes

- 1 Loose or damaged coaxial cable.
- 2 Poor television signal to the machine.
- 3 Incorrect channel scan lineup.

### Possible Remedies

- 1 Check for good video signal to the tuner.
  - a) Inspect jumper cable connecting fitness equipment to the video drop. If it is visibly damaged or disconnected, replace or reconnect. If it passes visual inspection, swap with a known good jumper cable. If the TV channel now appears, the cable is the cause. Replace the jumper cable. If the channel does not appear, perform the same check on the F connectors.
  - b) Inspect the cable that runs from the patch panel at the bottom of the machine to the console. If this is disconnected or damaged, reconnect or replace. If the cable passes visual inspection, use a known good cable to bypass this cable. If the TV channel appears, replace the coax cable running through the machine.
  - c) Connect the machine to a known good A/V drop. If the TV channel now appears on the console, verify the drop is good. If not, have the customer contact their A/V service technician to repair the drop.
  - d) Verify signal strength with signal meter.
- 2 As above, verify condition and connections of coax cables as well as verify quality of signal to that drop. Verify signal strength using a signal meter.
- 3 Rescan channels on that unit. This is less likely to be the problem if the channel is coming in poorly since if the console is looking at the wrong channel number entirely, this should manifest as a black TV screen rather than poor video quality.

## Green Screen

### Description

Entire touch screen is displaying a green color. No response to any inputs, machine is completely unusable.

### Possible Causes

- 1 Operation System, kernel crash. Operating System is completely hung up, no error logging is able to occur.

### Possible Remedies

- 1 Reboot machine. Upgrade software to latest version.



## Stuttering Channels

### Description

TV channels stutters and skips regularly every second or so. Video and audio skip together. If the skipping channel is left on, the TV may go black for a short time and the mediaapp will be reset by the system.

### Possible Causes

- 1 Tuner tuned improperly to the channel

### Possible Remedies

- 1 Change the channel to a different channel. The skipping will now be gone and the user can change back to the original channel.

## Touch Screen Slow Response

### Description

Touch screen responds appropriately to touches, but does so slowly. The screen may or may not play the animations associated with the touches when carrying out the appropriate action.

### Possible Causes

- 1 The console is running low on memory.

### Possible Remedies

- 1 Reboot the console. This will clear the memory and restore the unit to normal operation.

# Touch Screen Responds Incorrectly to Touch or is Unresponsive

## Description

Touch screen reads touches, but it is not registering them where the user is touching the screen.

## Possible Causes

- 1 The touch screen was improperly calibrated or has fallen out of calibration.
- 2 Console has locked up.
- 3 Touch Screen is defective.

## Possible Remedies

- 1 Recalibrate the P80 screen. See the screen calibration procedure below.
- 2 Reboot the machine.
- 3 If the touch screen has failed entirely, console will need to be replaced. This is not a replaceable part.

## Screen Calibration Procedure

- 1 The **Welcome** screen will be the first screen you see when the P80 console boots up.
- 2 From the Welcome screen, press the Pause key and continue holding it down while you press in sequential order an U configuration on the Volume and Channel key pad (① Channel Up, ② Channel Down, ③ Volume Down, ④ Volume Up). Release the Pause key when done pressing the arrows.
- 3 Touch each + while facing the P80.

## Poor Quality Video - One Channel or Limited Channels

### Description

One or a limited number channels on a unit has poor reception or no reception.

### Possible Causes

- 1 Loose or damaged coaxial cable.
- 2 Poor television signal to the machine.
- 3 Incorrect channel scan lineup.

### Possible Remedies

- 1 Check for good video signal to the tuner.
- 2 Inspect jumper cable connecting fitness equipment to the video drop. If it is visibly damaged or disconnected, replace or reconnect. If it passes visual inspection, swap with a known good jumper cable. If the TV channel now appears, the cable is the cause. Replace the jumper cable. If the channel does not appear, perform the same check on the F connectors.
- 3 Inspect the cable that runs from the patch panel at the bottom of the machine to the console. If this is disconnected or damaged, reconnect or replace. If the cable passes visual inspection, use a known good cable to bypass this cable. If the TV channel appears, replace the coax cable running through the machine.
- 4 Connect the machine to a known good A/V drop. If the TV channel now appears on the console, verify the drop is good. If not, have the customer contact their A/V service technician to repair the drop.
- 5 Verify signal strength with signal meter.
- 6 As above, verify condition and connections of coax cables as well as verify quality of signal to that drop. Verify signal strength using a signal meter.
- 7 Rescan channels on that unit. This is less likely to be the problem if the channel is coming in poorly since if the console is looking at the wrong channel number entirely, this should manifest as a black TV screen rather than poor video quality.

## Poor Audio Quality – All Channels, Multiple Units

### Description

One or a limited number channels on a unit has poor reception or no reception.

### Possible Causes

- 1 Loose or damaged coaxial cable.
- 2 Poor television signal to the machine.
- 3 Incorrect channel scan lineup.

### Possible Remedies

- 1 Check for good video signal to the tuner.
- 2 Inspect jumper cable connecting fitness equipment to the video drop. If it is visibly damaged or disconnected, replace or reconnect. If it passes visual inspection, swap with a known good jumper cable. If the TV channel now appears, the cable is the cause. Replace the jumper cable. If the channel does not appear, perform the same check on the F connectors.
- 3 Inspect the cable that runs from the patch panel at the bottom of the machine to the console. If this is disconnected or damaged, reconnect or replace. If the cable passes visual inspection, use a known good cable to bypass this cable. If the TV channel appears, replace the coax cable running through the machine.
- 4 Connect the machine to a known good A/V drop. If the TV channel now appears on the console, verify the drop is good. If not, have the customer contact their A/V service technician to repair the drop.
- 5 Verify signal strength with signal meter.
- 6 As above, verify condition and connections of coax cables as well as verify quality of signal to that drop. Verify signal strength using a signal meter.
- 7 Rescan channels on that unit. This is less likely to be the problem if the channel is coming in poorly since if the console is looking at the wrong channel number entirely, this should manifest as a black TV screen rather than poor video quality.

## Machine Controls Unresponsive

### Description

Machine controls do not respond to input. User is unable to change workout parameters.

### Possible Causes

- 1 Cable from machine controls to upper board is damaged or not inserted properly.
- 2 Machine controls have failed

### Possible Remedies

- 1 Check yellow/black cable in console for damage. Ensure the cable is inserted fully onto the pins. If not inserted properly, insert. If cable is damaged, console must be replaced; this is not a replaceable part.
- 2 If machine controls have failed, the entire console will need to be replaced. This is not a replaceable part.

## Message Out of Service Displayed

### Description

Console is displaying a message that says Temporarily Out of Service. Please use another machine.

### Possible Causes

- 1 Software has encountered an error causing the console to enter Out of Service mode
- 2 The Auto Stop sensor on a treadmill is missing, improperly installed, or malfunctioning (Treadmill Only).

### Possible Remedies

- 1 Reboot the console. Most issues causing Out of Service errors will be cleared from a reboot.
- 2 Treadmill Only. Inspect the Auto Stop sensor and ensure it is installed properly. Inspect Auto Stop cable to ensure it is inserted properly and undamaged. Repair or replace if needed. OOS error will clear as soon as the sensor is detected. Do not disable the Auto Stop sensor in the software. For more trouble shooting information on the Auto Stop feature see Troubleshooting- TRM\_ Trouble Shooting the Auto Stop Feature.

## **Message Please Reset the Treadmill Displayed**

### **Description**

On a treadmill, the screen displays the message, Please Reset the Treadmill along with a graphic of the stop switch.

### **Possible Causes**

- 1 The Stop Switch lanyard has been pulled and the reset latch has been disengaged. The yellow button will be raised on the dash.
- 2 The stop switch reset latch has been engaged, but not fully so.
- 3 The cable connecting the stop switch to the console is disconnected, loose, or damaged.
- 4 The stop switch is malfunctioning.
- 5 The lower board has failed.

### **Possible Remedies**

- 1 Press down firmly the yellow button on the dash. The tread will reset itself shortly.
- 2 Pull the lanyard to disengage the reset latch. Press down firmly on the yellow button on the dash to reset the treadmill.
- 3 Inspect the connections leading from the stop switch to the console. Ensure that the cables are secure and undamaged.
- 4 Replace the lower board.
- 5 Replace the stop switch assembly.



## Unit reboots of its own volition

### Description

Console fully reboots without any outside input, either during the boot process or while in operation.

### Possible Causes

- 1 Power connections outside fitness equipment are loose or bad
- 2 Power connections inside fitness equipment are loose or bad
- 3 Faulty power supply
- 4 Facility power is not configured correctly.
- 5 Faulty console

### Possible Remedies

- 1 Inspect power cord from wall plate to power supply (if non-Treadmill) or patch panel (if Treadmill). Verify all connections are tight and that there is no damage. Swap with known good cable, if appropriate. Inspect connections from power supply to patch panel (if non-Treadmill). Reconnect or replace all cables as needed.
- 2 Open the machine and inspect the power cord running from patch panel to console (if non-Treadmill) or from patch panel to power supply (if Treadmill). Swap with known good to test, if needed. On Treads, also check from power supply to console. Again, swap with known good to test.
- 3 Inspect power supply for damage. Swap with known good power supply to test. Replace, if needed.
- 4 Ensure that facility has configured their power correctly. About 8 non treadmill units can be connected through one dedicated circuit. Each treadmill must be on a dedicated, branch circuit. Neutrals and Hot Leads must not be shared among treadmills. If the power supplied to the machines is not up to specification, the customer will need to contact an electrician to make the needed repairs.
- 5 If the power, power supply, and power cabling are all good and securely connected, the console will need to be replaced.

## **Treadmill - Resets to Welcome Screen at Beginning of the "3...2...1..." Countdown**

### **Description**

After pressing "Quickstart" the console will start the "3...2...1..." countdown, but reverts back to the "Welcome" screen immediately after the "3..."

### **Possible Causes**

- 1 Stop switch damaged or faulty.
- 2 Stop switch wiring damaged or faulty.
- 3 Stop switch stuck in the in the engaged position.

### **Possible Remedies**

- 1 Replace stop switch.
- 2 Verify that the cable connectors are seated properly and ohm out the cable for continuity. If an open is detected in the cable, replace stop switch cable.
- 3 Replace the stop switch.

# USB Flash Drive Not Recognized

## Description

The P80 has failed to recognize the USB flash drive. This could have been discovered during a software update attempt, or during an import or export operation.

## Possible Causes

- 1 External USB port PCB failure.
- 2 External USB port cable failure.
- 3 Internal P80 failure.

## Possible Remedies

- 1 Replace External USB port PCB, Part # 40003-403
- 2 The External USB port cable is behind the armor and will require replacement of the entire P80.
- 3 Replace the entire P80.



---

# Section 11 - Replacement Procedures

---

The following components can be replaced in the field.

## Upper Component Access:

There is a small cover that fits on the top portion of the rear of the console. This cover conceals 4 replaceable components, the RFID board, the WiFi Module, the iPod Cable, and the External USB Port.

*Figure 63: P80 Top Access Panel & Components*

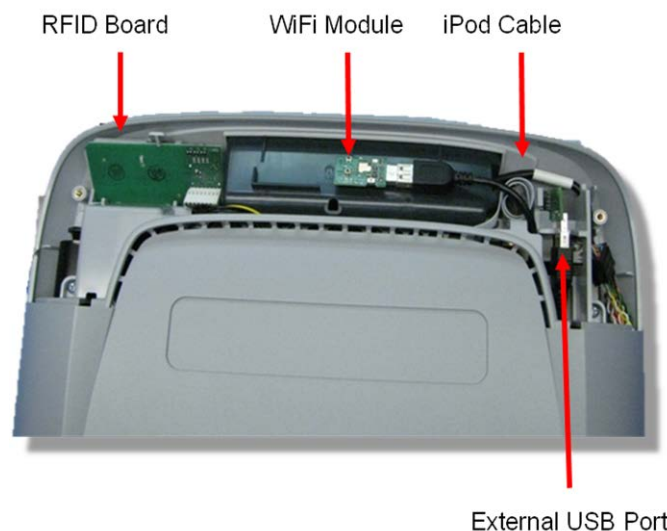

**The RFID Board** is held in place by plastic clips, and connected using a single cable.

**The WiFi Module** (not currently supported by the software) is held in with double stick mounting tape, and is connected via a USB cable.

**The iPod Cable** is the cable that the users will handle when plugging in their iPhone or iPod, and therefore will need occasional replacement. It plugs into another cable that leads from behind the armor.

**The External USB port** is mounted on a board that clips into the front port opening. It connects via a USB cable.

## The Main Vented Access Cover & Components

Behind the main vented access cover, are 3 components that can be replaced in the field (the DC Power Splitter Cable, the TV Tuner USB Cable, and the Heart Rate Board), plus the Headphone Board at the bottom of the console.

*Figure 64: Main Vented Access Cover*

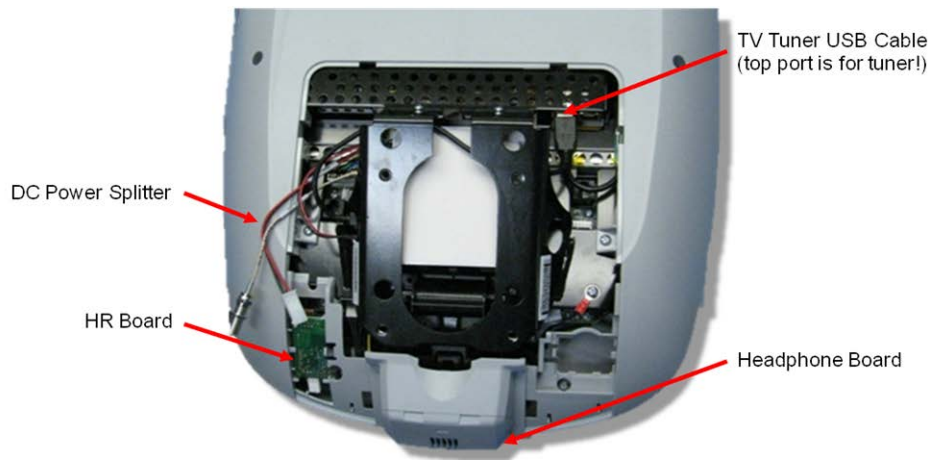

**The DC Power Splitter** is used only in earlier hardware revisions of P80 consoles. It splits the power between the TV Tuner and the rest of the console.

**The TV Tuner USB Cable** connects the TV tuner to the top USB port. It is routed behind the mounting plate portion of the armor to avoid getting pinched by the mounting plate.

**The Heart Rate Board** snaps into clips in the console, and connects with 2 cables. There is a 3 pin cable connector at the bottom of the board that leads behind the armor, and there is a 4 pin cable connector at the top of the board that leads to the heart rate grips.

**The Headphone Board** connects via a signal cable and a ground wire that snaps onto a ground lug. The board then snaps into a plastic housing that then snaps onto the bottom of the console.

## Replacing the P80 Console

### Console Mounting - Removal

- 1 Remove the rear vent cover. Do not use a sharp tool, such as a flat bladed screwdriver, to pry up the cover, as you can damage the covers and possibly components inside the console. When the cover starts to come loose, gently unsnap it from the P80 and set it aside where it will not be scratched.

*Figure 65: P80 Rear Cover Removal*



- 2 Remove the four flat head 5/8 inch long screws that secure the console to the plate.

*Figure 66: Console Mounting Screws*



Tilt the console forward (away from yourself) on the mounting hook.

*Figure 67: Maintenance Access Hook*

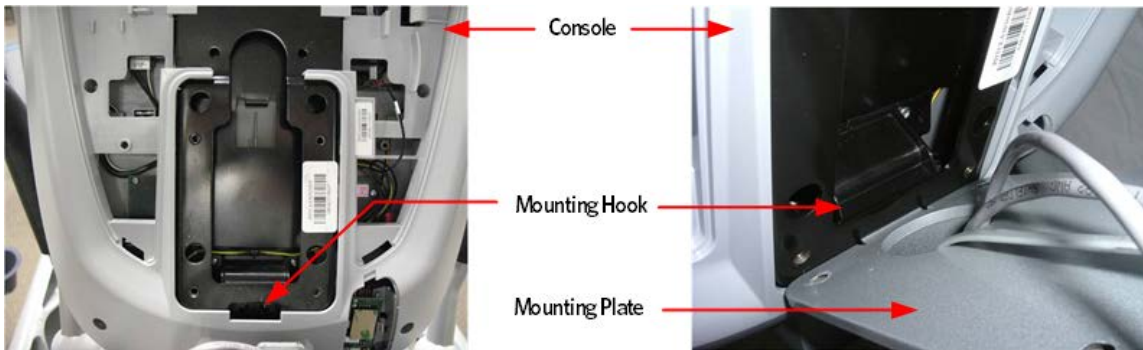

## Disconnecting Cables

- 1 Locate the coax connector and cut the wire tie that secures the coax connector to the console armor. Disconnect the coax cable connector from the consoles flexible coax cable connector.

*Figure 68: Coax Cable*

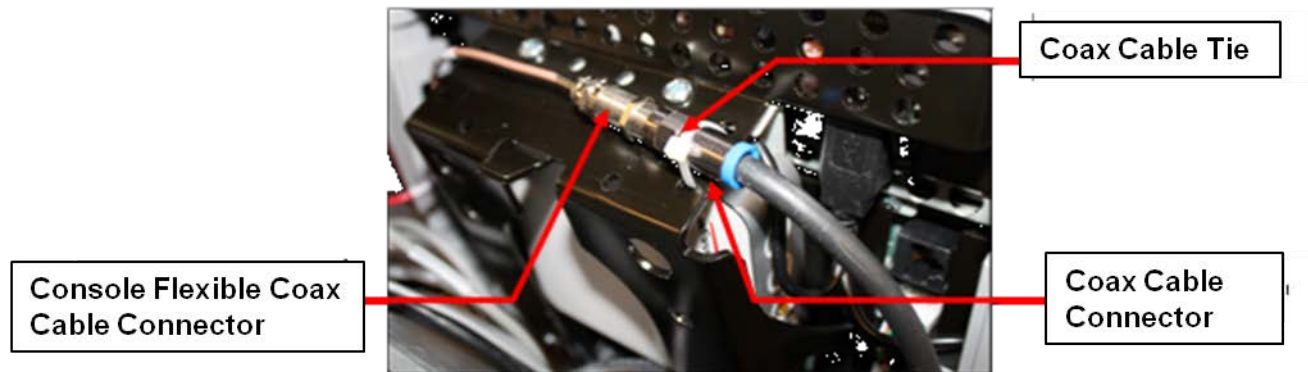

- 2 Disconnect the Ethernet cable, Data cable, the Power cable, HR cable, Auto Stop cable (Treadmill only), and Stop Switch cable (Treadmill only).



*Figure 69: Disconnecting Cables*

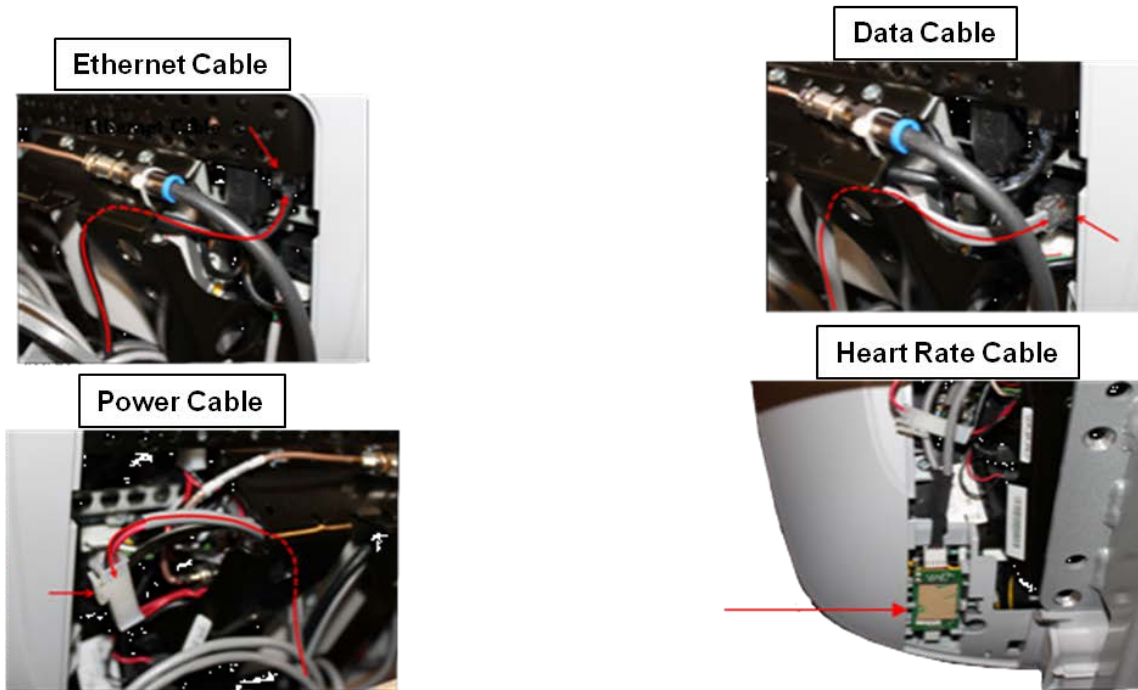

*Figure 70: Auto Stop Cable Routing*

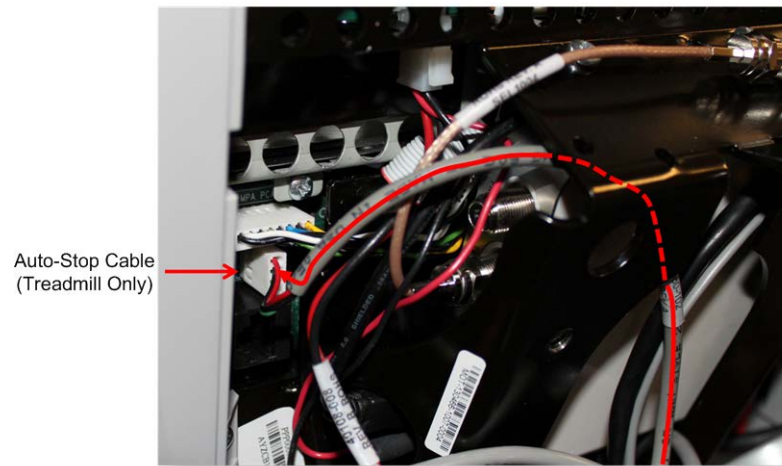

*Figure 71: Stop Cable Routing (Treadmill Only)*

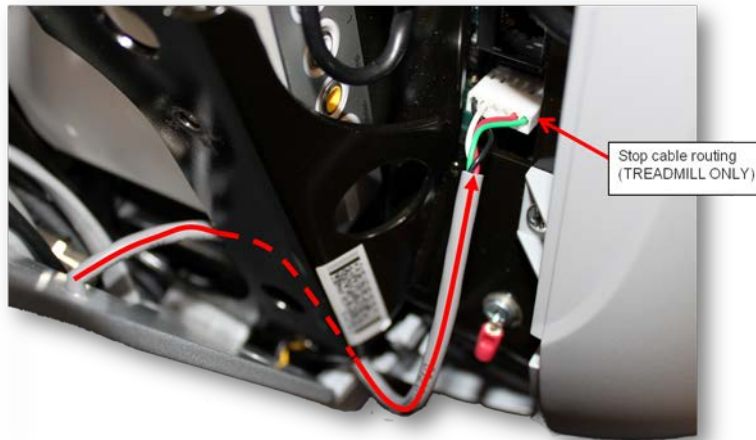

- 3 Remove the console by lifting it off the mounting hook.

### **Console Installation**

- 1 In the back of the P80 console there is a large black steel support called the Armor. At the bottom of Armor there is a notch about  $\frac{1}{4}$  inches in depth and about  $1\frac{1}{2}$  inches across. Set the console notch over the over the mounting hook.

---

***Note: Before releasing the console insure the notch is securely seated over the mounting hook.***

---

*Figure 72: Console on Mounting Hook*

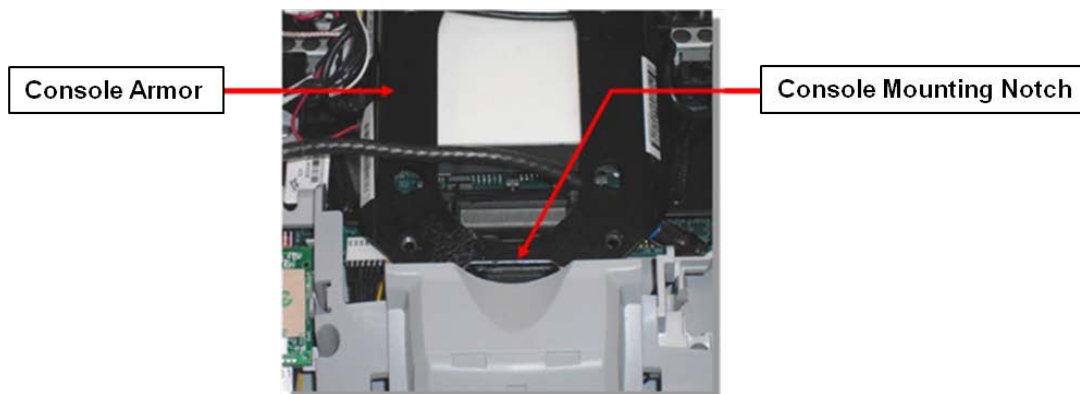

## Cable Connections

- 1 Route the RF coax cable down below the tuner and out the right bottom side of the armor. This is easier if you straighten the cable and gently push it in the direction as shown in diagram below. Feed about 10 inches of cable out though the plastic using your finger as a guide.
- 2 Bring the coax cable up over the top of the armor and connect it to the flexible cable attached to the tuner.
- 3 Secure the RF coax connectors in place with a zip tie.

***Note: It is important that the connection be tied to the frame in this location to prevent the cable from being pinched, and the possibility of rattling noises during use. Be sure to secure the zip tie on the connector and not on the cable.***

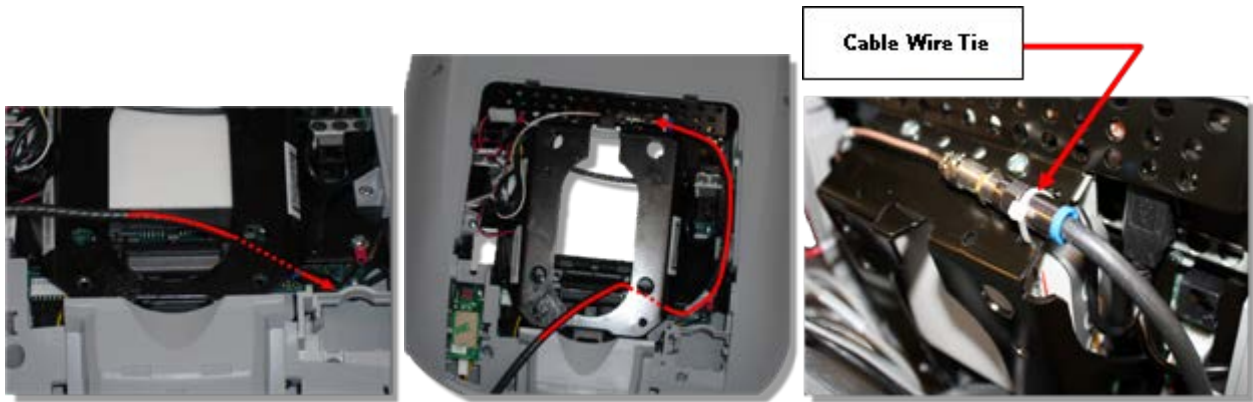

- 4 Route the black, round Ethernet cable through the opening in the upper right side of the armor, behind the tuner and connect the Ethernet cable to the upper RJ45 type connector.
- 5 Route the grey, flat Data cable through the opening in the upper right side of the armor, behind the tuner and connect the Data cable to the lower RJ45 type connector.

*Figure 73: Cable Connections*

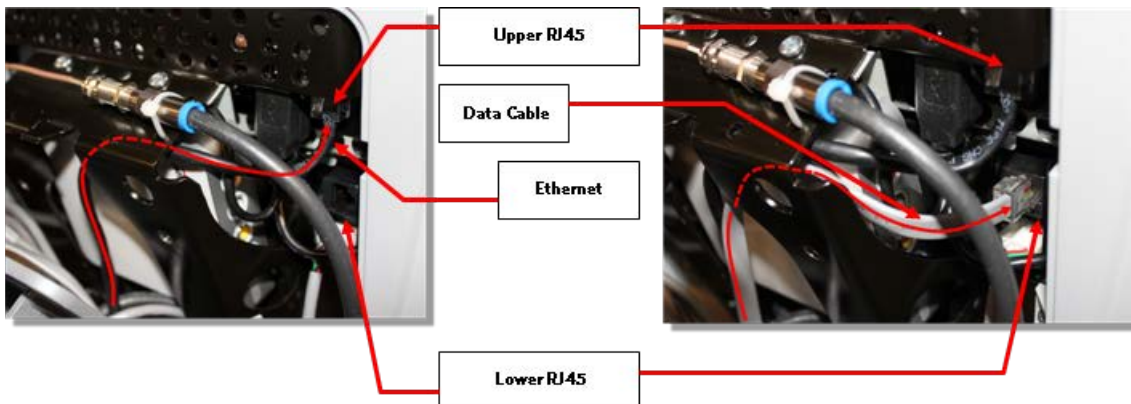

- 6 Route the Power cable through the upper left corner of the weldment and connect it to the P80 power connector.

---

***Note: Leave the connector on the side of the P80 as shown in below, as it might be necessary to access it for troubleshooting.***

---

*Figure 74: P80 Power Cable Routing*



- 7 Route the Heart Rate cable through the upper left corner of the weldment and connect it to the HR PCA. Route any excess Heart Rate cable into the rectangular center section of the dash assembly.

*Figure 75: P80 Heart Rate Cable Routing*

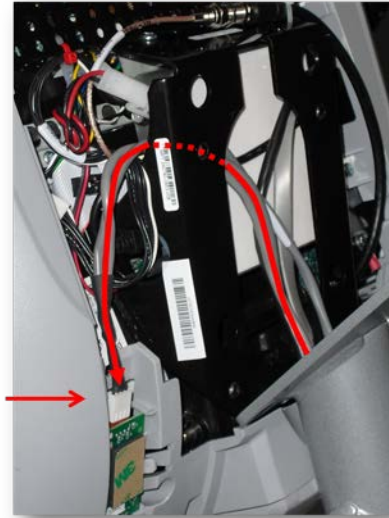

- 8 If applicable, route the Auto Stop cable through the upper left corner of the weldment and connect it to the Auto Stop connector.

*Figure 76: Auto Stop Cable Routing*

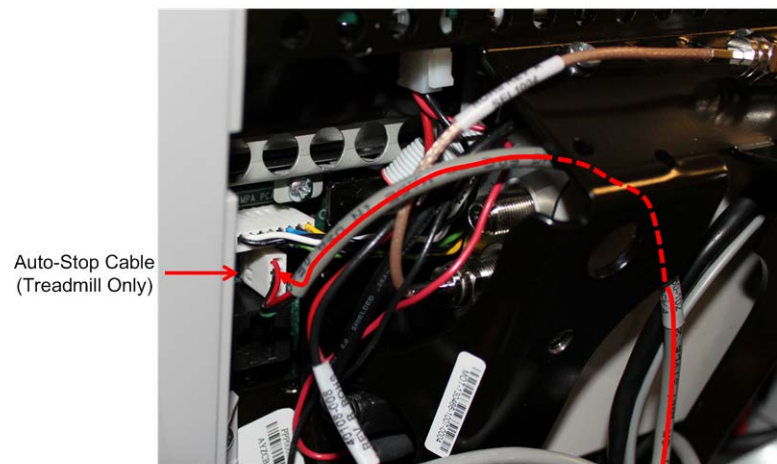

- 9 If applicable, route the Stop Switch cable (Treadmill only) through the bottom right corner of the weldment and connect it to the Stop Switch connector.

*Figure 77: Stop Cable Routing (Treadmill Only)*

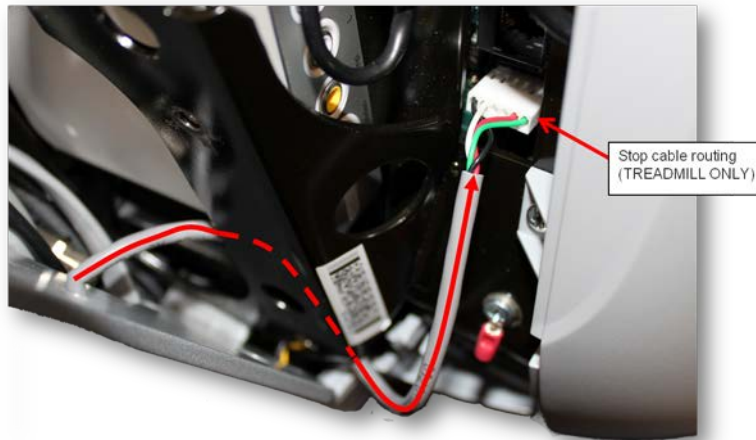

## Securing the P80 Console

- 1 Make sure that all cables are fully and securely connected, and that cables are tied back properly. Make sure any extra cabling is pulled down through the neck and along the front of the dash, making sure the cables are routed through the plastic guides inside the neck.
- 2 Tilt the control console backward (toward yourself) until the tab on the top edge of the armor slides along the top edge of the console mount and the screw holes align properly.
- 3 Secure the console to the plate using the four flat head 5/8 inch long screws.

---

***Note: You must use 5/8 inch long screws. If the screws are too short the console will not be properly grounded. If the screws are too long it is possible to damage the internal wiring***

---

- 4 Tighten the screws fully using a  $\frac{5}{32}$ -inch hex wrench.
- 5 Replace the rear vent cover.

## Replacing the P80 Heart Rate PCA Board

### Procedure

- 1 Remove the rear vent cover. Do not use a sharp tool, such as a flat bladed screwdriver, to pry up the cover, as you can damage the covers and possibly components inside the console. When the cover starts to come loose, gently unsnap it from the P80 and set it aside where it will not be scratched.

*Figure 78: P80 Rear Cover Removal*



- 2 The PCA's in the console are static sensitive. They can be damaged if proper static prevention equipment is not used. Attach an anti-static wrist strap to your arm, and then connect the ground lead of the wrist strap to frame ground.
- 3 The HR PCA snaps into its mounting. Press the release tab sideways and remove the HR PCA from its mounting.
- 4 Disconnect the HR cable and handlebar cable from the HR PCA.
- 5 Connect the HHR Grip cable assembly to the upper connector on the HR PCA and the HR PCA Power cable to the lower connector on the replacement HR PCA.
- 6 Orient the replacement HR PCA so that the side with the protective foam pad is facing out and snap the HR PCA into its mounting.

*Figure 79: P80 Heart Rate PCA Board*

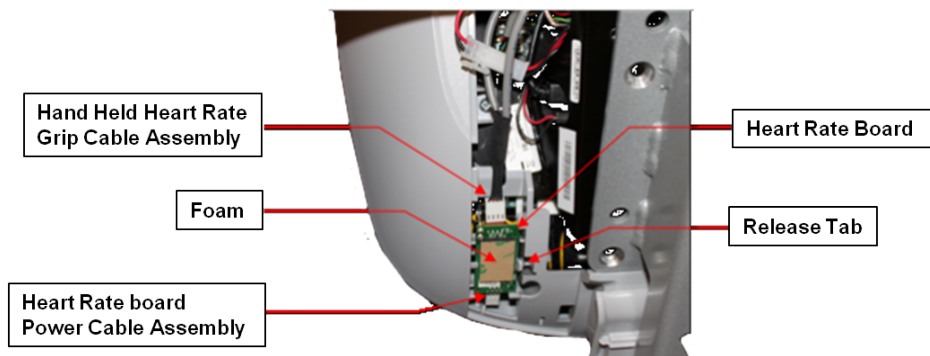

- 7 Replace the rear vent cover.
- 8 Check operation per procedure, ***Section 3 - Operation Verification*** (on page 21) .





# Section 12 - Wiring & Block Diagrams

Figure 80: Wiring Diagram Main

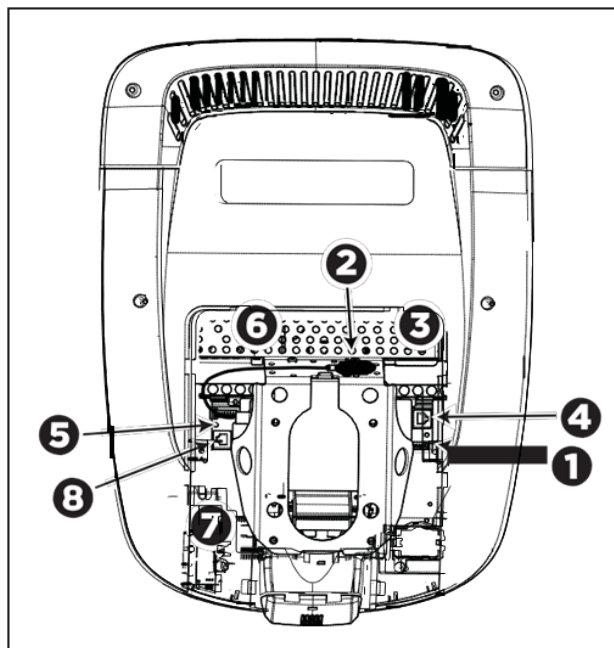

Cable	Connector Type	Circuit Connector
Safety Key (Treadmills only)	Six-contact strip, keyed	①
TV in	F-type coaxial	②
Ethernet (LAN)	Eight-contact modular / round / black cable	③
Data from base unit	Eight-contact modular, on flat fray cable	④

Cable	Connector Type	Circuit Connector
Automatic stop sensor (treadmills only)	Four-contact strip, keyed	<b>5</b>
Power	Two-contact plug, polarized and latched	<b>6</b>
Heart rate sensors	Four-contact strip, keyed	<b>7</b>
CSAFE	Eight-contact modular, on flat gray cable	<b>8</b>

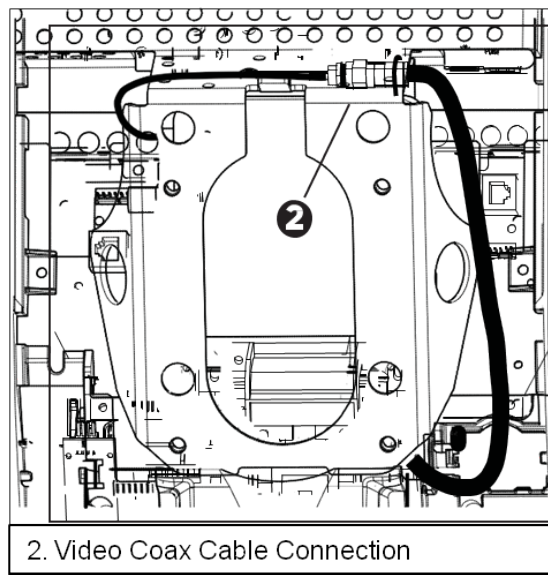
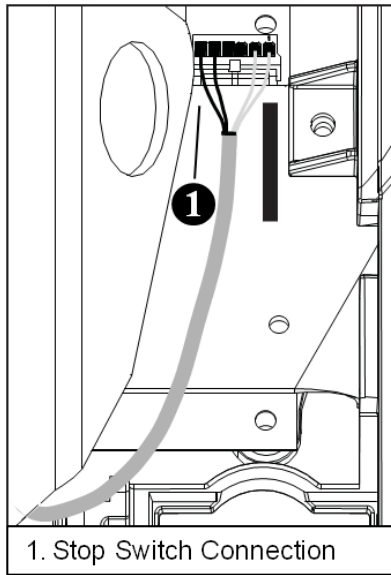

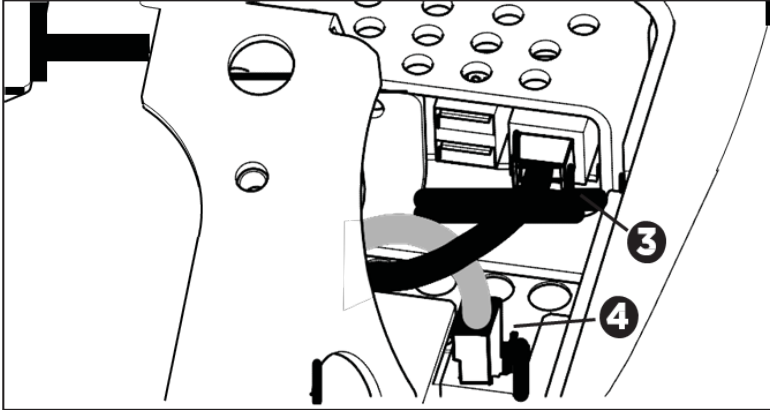

3. Network Cable Connection

4. Data Cable Connection

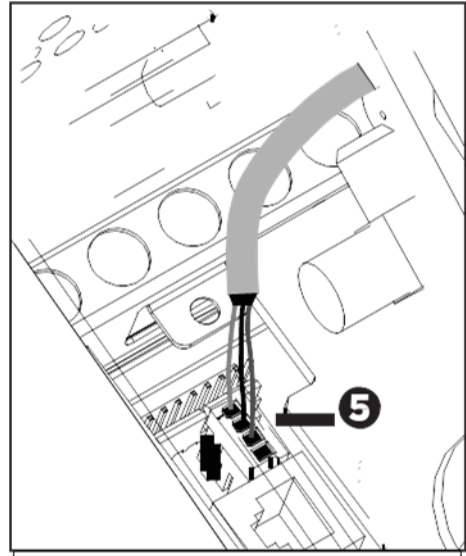

5. Auto-Stop Cable Connection

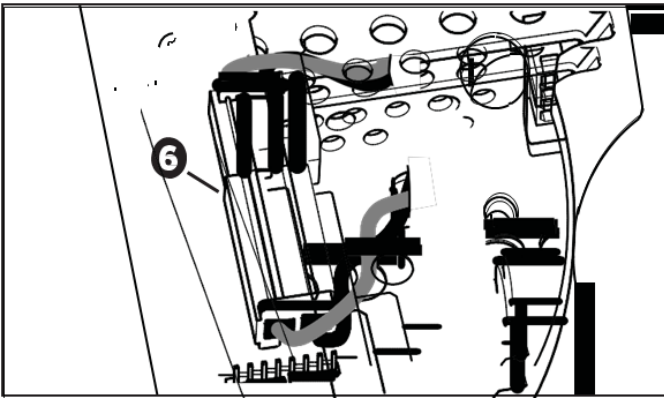

6. Power Cable Connection

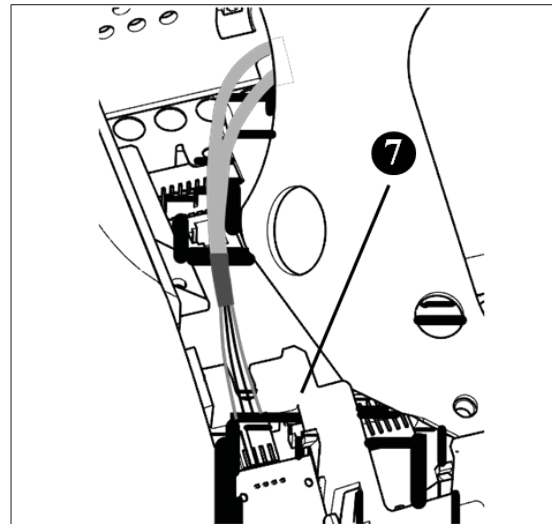

7. Hand Held Heart Rate Cable Connection



# Section 13 - Replaceable Parts Identification

*Figure 81: P80 Top Access Components*

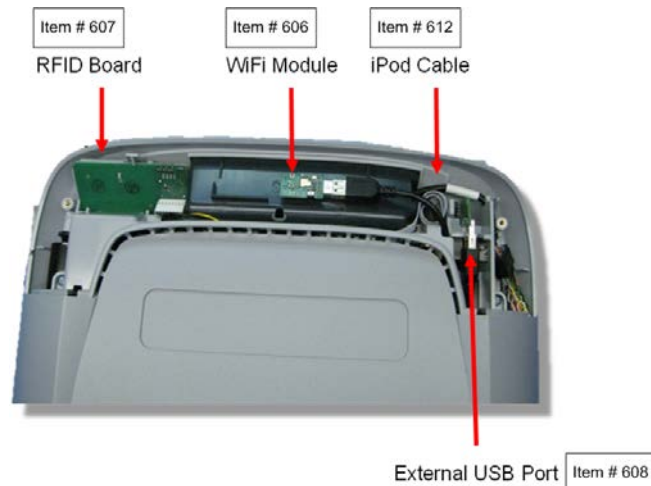

*Figure 82: Main Vented Access Components*

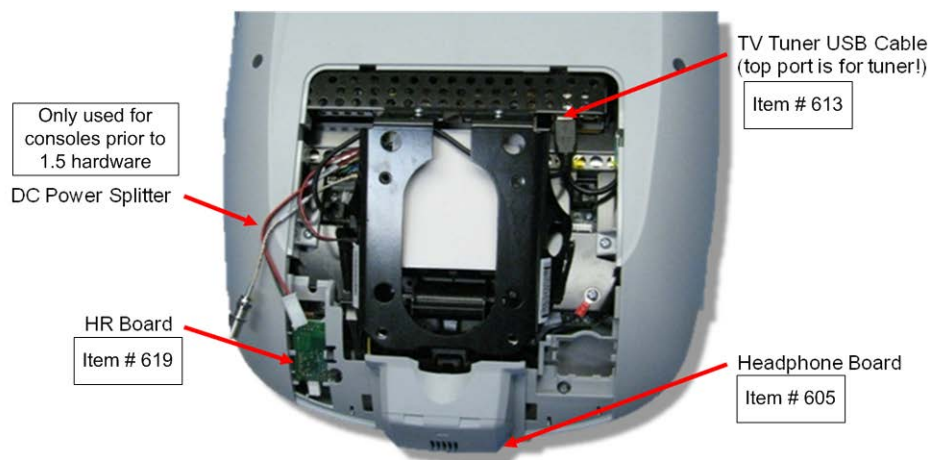

<b>Part Number</b>	<b>Description</b>	<b>Bubble Number</b>
PPP000000300302104	PLASTIC,REAR,DISPLAY -P80	601
PPP000000300306103	PLASTIC, IPOD ACCESSORY TRAY,DISPLAY - P80	602
PPP000000300303101	PLASTIC,ACCESS PANEL,UPPER,DISPLAY	603
PPP000000300305103	PLASTIC,BEZEL,LOWER VENT,DISPLAY -	604
PPP000000300204105	ASSY, HEAD PHONE JACK, P20/P30 - 91	605
PPP000000300313101	MODULE, 802.11B/G/N WIRELESS LAN US	606
PPP000000300181406	PCA, ATLAS_RFID_MODULE_2_TURN	607
PPP000000040003403	PCA,REPLACEABLE,USB BOARD,P80	608
PPP000000301528007	ASSY,CBL,A/V INTERFACE, ACC PWR,30P	612
PPP000000012478014	ASSY,CBL,USB 2.0, A MALE/B MALE,BLA	613
PPP000000040010008	ASSY,CBL,1C,20AWG,#8 RING/.110X032	618
PPP000000300812101	BOARD, CHR & WIRELESS, SALUTRON,100	619
PPP000000012865003	CABLE P-CLIP,OPEN ENDED,0.375" BUND	622
PPP000000040097006	ASSY,CABLE,COAX,MIL-F-17 M17/94-RG1	651
PPP000000302400341	LITERATURE KIT, P80 (ALL), EN	998